

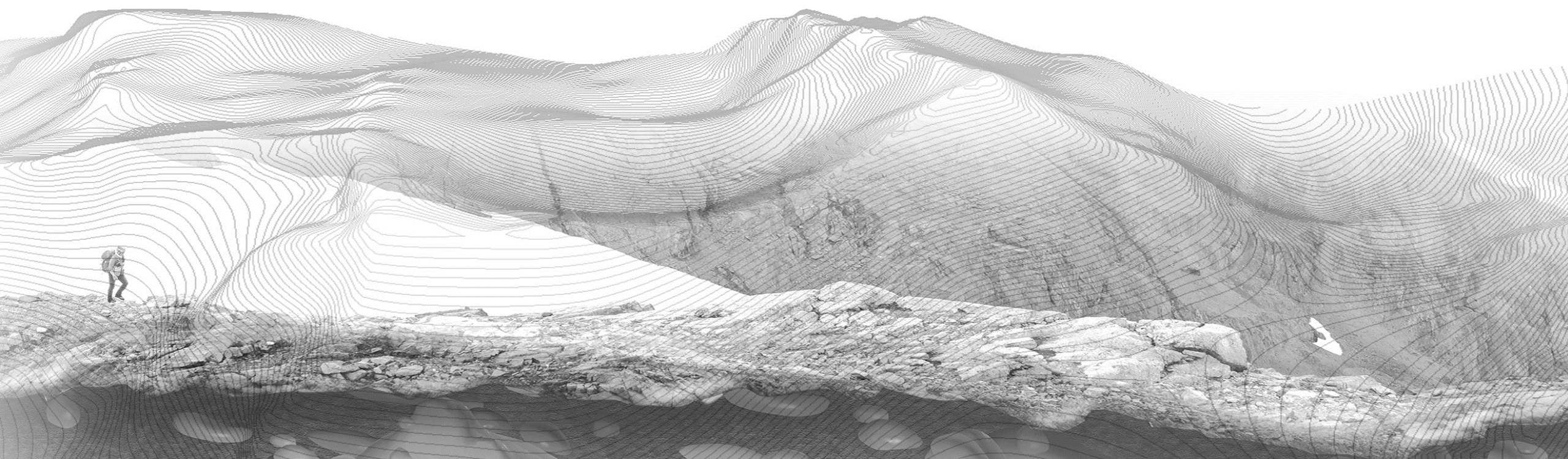

LEADING GROUND AND AIRBORNE GEOPHYSICS

TECHNOLOGIES



[DIASGEO.COM](http://DIASGEO.COM)

TORONTO VANCOUVER SASKATOON MEXICO CHILE AUSTRALIA

# AT A GLANCE

**SPECIALIZING IN RICH, HIGH-VOLUME DATA ACQUISITION**

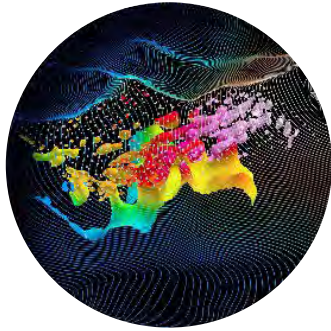

## 3D EARTH IMAGING

Patented 3D imaging systems  
With patented acquisition technology and SQUID sensor systems, Dias delivers uniquely dense, rich data sets.

**SURVEY DESIGN OPTIMIZATION**

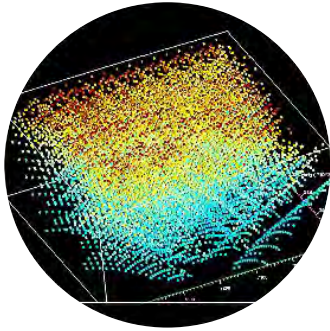

## BIG DATA FOR ACCURATE, RESOLVED, DEEP MODELS

The 'big data' we acquire allows us to produce highly accurate and resolved deep images of the subsurface.

**SURVEY EXECUTION**



## VERTICALLY INTEGRATED TO DESIGN, BUILD, DEPLOY

From gap analysis to data delivery, and design to manufacture, Dias controls its own destiny for its products.

**DATA PROCESSING INITIAL MODELING**



## WORLDWIDE OPERATIONAL EXCELLENCE

With experienced leadership and a global presence and partners, Dias has successfully deployed around the world.



## DIAS CARAVEL LEVERAGING BIG DATA

A cloud service for the processing and 3D inversion of 'big data' powered by machine learning and custom codes.



## EMERGING TECHNOLOGIES STRONG R&D PIPELINE

Dias has deployed the DIAS32 system, MT, QMAG<sup>T</sup> and QAMT airborne system. Coming soon - QTEM, DIASEM.

## CONTENTS

- 2 AT A GLANCE
- 3 TECHNOLOGIES
- 4 TIMELINE
- 5 PROJECTS MAP
- 6 OVERVIEW
- 7 SAFETY
- 8 SAFETY

- 9 TECHNOLOGIES CLICKABLE
- 10 DIAS32
- 15 MAGNETOTELLURICS
- 18 ELECTROMAGNETICS EM
- 19 JESSY DEEP SQUID TEM
- 21 SURFACE EM SURVEY MODES
- 22 HIGH POWER BOREHOLE
- 24 IN-MINE BOREHOLE

- 25 IN-MINE BOREHOLE
- 26 HELIWINDER
- 28 QMAGT
- 44 SUB-AUDIO MAGNETICS
- 46 HELISAM
- 49 SAMSON
- 51 UAV SAM
- 53 CONTACTS

- 54 CASE STUDY QMAGT – LITHIUM
- 55 CASE STUDY QMAGT – LITHIUM
- 56 CASE STUDY DIAS32 – URANIUM
- 57 CASE STUDY DIAS32 – URANIUM
- 58 CASE STUDY DIAS32 – GOLD
- 59 CASE STUDY DIAS32 – GOLD
- 60 3D VS 2D COMPARISON
- 61 CASE STUDY DIAS32 – GOLD/SILVER
- 62 CASE STUDY DIAS32 – GOLD





### DIAS32

HIGH POWER 3D INDUCED POLARIZATION (IP) & RESISTIVITY SURVEYS  
Ground-breaking IP and resistivity system for high resolution and deep search 3D surveying.



### MAGNETOTELLURICS (MT)

MAGNETOTELLURICS (MT)  
Produces a 3D resistivity model of the ground by recording naturally occurring electric and magnetic fields at the surface.



### QMAGT

AIRBORNE FULL-TENSOR MAGNETIC GRADIOMETRY (FTMG) Dias Airborne's QMAGT system is the most advanced airborne magnetic system currently commercially available.



### HIGH POWER BOREHOLE EM

ELECTROMAGNETIC  
High-powered, deep search technology produces highest quality downhole data.



### ELECTROMAGNETICS

(EM) Moving & Fixed Loop  
Dias EM surveys use proprietary JESSY DEEP **SQUID** Sensors - World's most sensitive sensor for vector transient electromagnetic measurements. Detects deeper conductors, 1 km or more.

### SUB AUDIO MAGNETICS SAM

This proprietary survey technique uses a total field magnetometer at high sample rates to produce low noise EM measurements. SAM surveys are flexible, with several modes, including stationary EM, walking, towed, drone, and helicopter.



#### UAV SAM

UAVSAM refers to semi-airborne acquisition of the SAM geophysical technique, using an Unmanned Aerial Vehicle (UAV).



#### SAMSON

SURFACE EM SUB-AUDIO MAGNETICS  
A proprietary method using SAM magnetometer sensor in a ground EM deployment



#### HelisAM

AIRBORNE EM SUB AUDIO MAGNETICS  
Perfect method for detection of large-tonnage VMS / Cu-Ni-PGM ore bodies to great depth

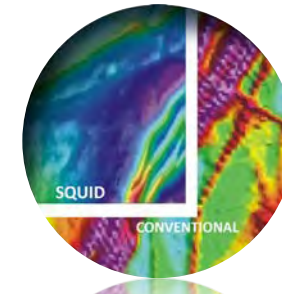

### SQUID SENSORS

HIGH AND LOW TEMPERATURE SQUID. Superconducting Quantum Interference Device (SQUID)  
Direct B-field measurement at low frequency (0.125 to 5.0 Hz)



### Heli WINDER

The HeliWinder series have been constructed to allow crews to lay out wire across even the most treacherous terrain which allows for the deployment of loops to be a lot faster and safer with the use of much smaller crew sizes.



# DIAS TIMELINE



2014 Dias Geophysical is founded with offices in Toronto and Saskatoon. Company values

- Safety
- Innovation
- Transparency
- Integrity
- Resolve

2014

2014 Patents issued for the CVR (Common Voltage Reference) method which allows multi-scale dipoles & improved survey efficiencies & reduced health & safety risks.



2015



2015 Introduction of DIAS32 - the first fully distributed, wireless IP & resistivity system using CVR technology. Provides revolutionary model accuracy & reliability. Wireless communication for real time quality assurance. Battery life & compact design improve survey productivity & safety.

2015 First commercial survey. Thanks to Rio Tinto for their consistent support of new technologies.



2015 Improvements in the wireless control protocols & data processing for DIAS32.

2016

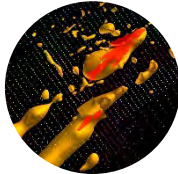

2016 DIAS32 is used for some of the world's largest 3D resistivity surveys with more than 10 million data records & 24 sq. km of coverage.

2016 Dias expands offices to Vancouver

2016 DIAS32 capacity increased to over 300 receivers.



2016 Second generation of DIAS32 receiver with a compact, rugged design & battery life of up to a week - productivity is greatly improved.

2017

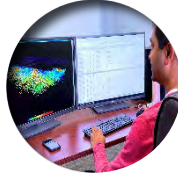

2017 Discovery of South Arrow Deposit. NexGen Energy tests a DIAS32 anomaly & discovers a new uranium deposit in the SW Athabasca basin near their world class Arrow Deposit.



2017 New tools for real time data analysis are introduced & a new processing environment for the data is completed. Continued refinements of DIAS32 system & expansion of operational capacity.

2018



2018 Largest 3DIP survey conducted (99 sq. km.) in the western United States.

2018 DIAS32 capacity increased to over 800 receivers.



2018 DIAS' GS5000 transmitter is introduced - 5000 V, 20 A & 25 kW weighing only 31 kg. Leading power to weight ratio, stackable to 100 kW of power optimizes current in any situation. Safety features include remote control & safe key system.

2019



2019 Introduction of QMAG<sup>T</sup> airborne full tensor magnetic gradient system.

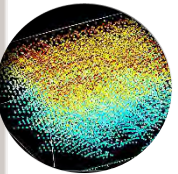

2019 Unique QMAG<sup>T</sup> technology images subtle magnetic features & enhances interpretation in remanent magnetic, low latitude, & complex structural environments.

2020

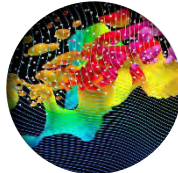

2020 Dias introduces its new generation of DIAS32 receivers featuring a more advanced processor and higher sample rates allowing for MT and CSAMT recording.

2020 A full suite of MT processing & inversion tools developed in house allows Dias to provide MT services using the most advanced methods.

2020 DIAS32 capacity increased to over 1100 receivers.



2020 Dias completes its first MT survey using the DIAS32 system.

2020 Dias expands to offices in Chile and Mexico.

2021



2021 Introduction of CARAVEL, a proprietary software that allows processing & inversion of high-volume 3D data sets. Client's access dedicated purpose-built hardware & leading inversion codes from a simple, easy to access interface.

2021 Dias moves head office to new facility with advanced R&D capabilities at 2131 Airport Dr., Saskatoon.

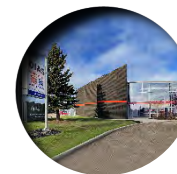

2022



2022 Dias introduces the QAMT system. Advanced SQUID magnetometer technologies, developed by Supracon AG of Germany. The QAMT uses atmospheric energy to image with higher resolution. This lightweight system provides access to challenging environments.

DIAS32 Capacity increased to over 1400 receivers

2022 Dias wins SABEX Award for growth.

2022 A truly global company, Dias has carried out commercial surveys in Argentina, Australia, Canada, Chile, China, Czech Republic, Dominican Republic, Greenland, India, Kazakhstan, Mexico, Peru, Mali, Saudi Arabia, West Africa & USA.



2023

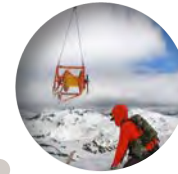

2023 Dias purchases Discovery Intl. Geophysics to expand their leading geophysical services to include: Semi-airborne HelisAM system, SQUID Electromagnetics, Borehole EM Technologies



2023 Dias "top notch" team credited with one of the most technically challenging surveys in BC history.



2024



2024 Dias celebrates 10<sup>th</sup> Anniversary of geophysical innovation and excellence.

2024 Dias introduces the next generation of DIAS32 receivers, bringing total to 2100



2024 Dias acquires Australian partner **Gap Geophysical** expanding capabilities and enhancing our unique services to global clients.



# MARKET LEADERSHIP – WORLDWIDE SURVEYS

Dias operates globally with offices in Toronto, Vancouver, Chile, Mexico, Australia and head-office in Saskatoon.

Dias has carried out hundreds of commercial surveys in Argentina, Australia, Canada, Chile, China, Czech Republic, Dominican Republic, India, Kazakhstan, Mexico, Peru, Mali, Saudi Arabia, West Africa and the USA.

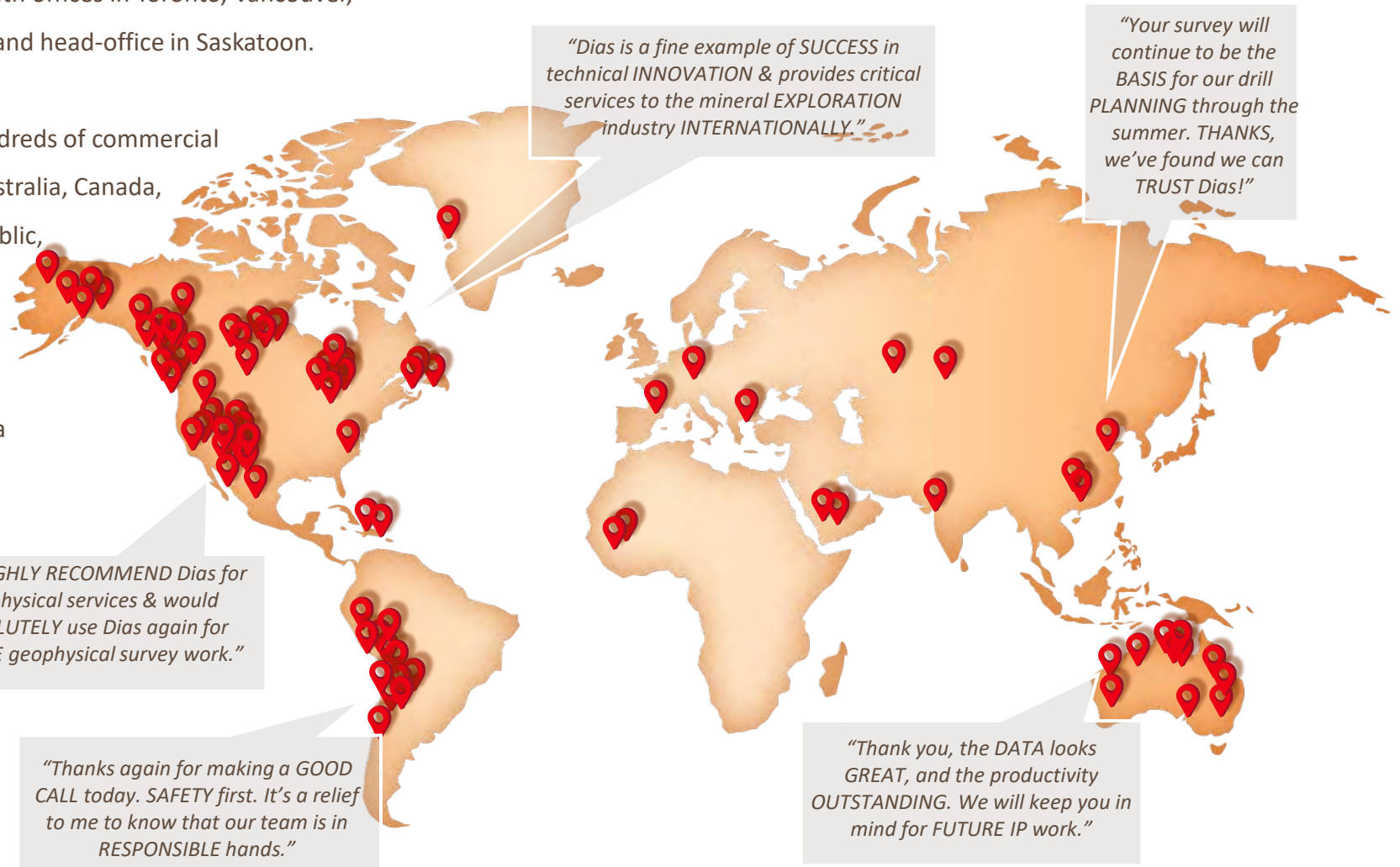

*"Dias is a fine example of SUCCESS in technical INNOVATION & provides critical services to the mineral EXPLORATION industry INTERNATIONALLY."*

*"Your survey will continue to be the BASIS for our drill PLANNING through the summer. THANKS, we've found we can TRUST Dias!"*

*"We HIGHLY RECOMMEND Dias for geophysical services & would ABSOLUTELY use Dias again for FUTURE geophysical survey work."*

*"Thanks again for making a GOOD CALL today. SAFETY first. It's a relief to me to know that our team is in RESPONSIBLE hands."*

*"Thank you, the DATA looks GREAT, and the productivity OUTSTANDING. We will keep you in mind for FUTURE IP work."*



# LEADING GROUND AND AIRBORNE GEOPHYSICS

**OUR TECHNOLOGY** and services help clients uncover valuable insights into the geological structure, lithology, and mineralization of their projects. Minerals such as Gold, Silver, Copper, Lithium, Uranium, Iron, Zinc and more may be detected by geophysical means.

**OUR TEAM** of geophysicists and engineers focus on new technologies and deliver ongoing development of our own proprietary systems.

**TRUSTED** by some of the largest companies in the world, Dias is able to collect bigger datasets to provide higher resolution imaging for subsurface exploration.

**WE BELIEVE** we have an obligation to ensure all staff are properly trained and educated to perform all tasks safely.

**WE DEPLOY** our professional crews with our leading-edge technology and a commitment to safety and operational excellence.



The safety and well-being of our team members and partners is one of Dias' core values.

We apply this value to all aspects of our business.

Dias is at the forefront of developing and producing our own equipment, which gives us the advantage of building in a way that prioritizes long-term safety and sustainability. We always choose our work to protect our field staff, our systems, our clients, and our surrounding environment. The Dias custom built transmitter (GS5000) is the most advanced in its class in the world, having the best power-to-weight performance in the market. Building our own also means that we can integrate customized safety features. We are also working on extreme fuel efficiency by adding an energy storage solution, so our fuel burn is approximately 75% less than that of other transmitters. It is also checked-baggage friendly, making it very portable for international operations.

## HSE PROCEDURES AND TOOLS

Dias has developed a comprehensive HSEC management system and implements this through our HSE manual and internet-assisted software: eCompliance. These modes facilitate implementation of HSE training, monitoring and management.

Dias implements the tools of WorkHub that make safety compliance interactive and engaging. This builds and ensures a culture of safety.

Dias is an active member of the Ground Geophysical Survey Safety Assoc. (GGSSA) and the Intl. Airborne Geophysics Safety Assoc. (IAGSA)

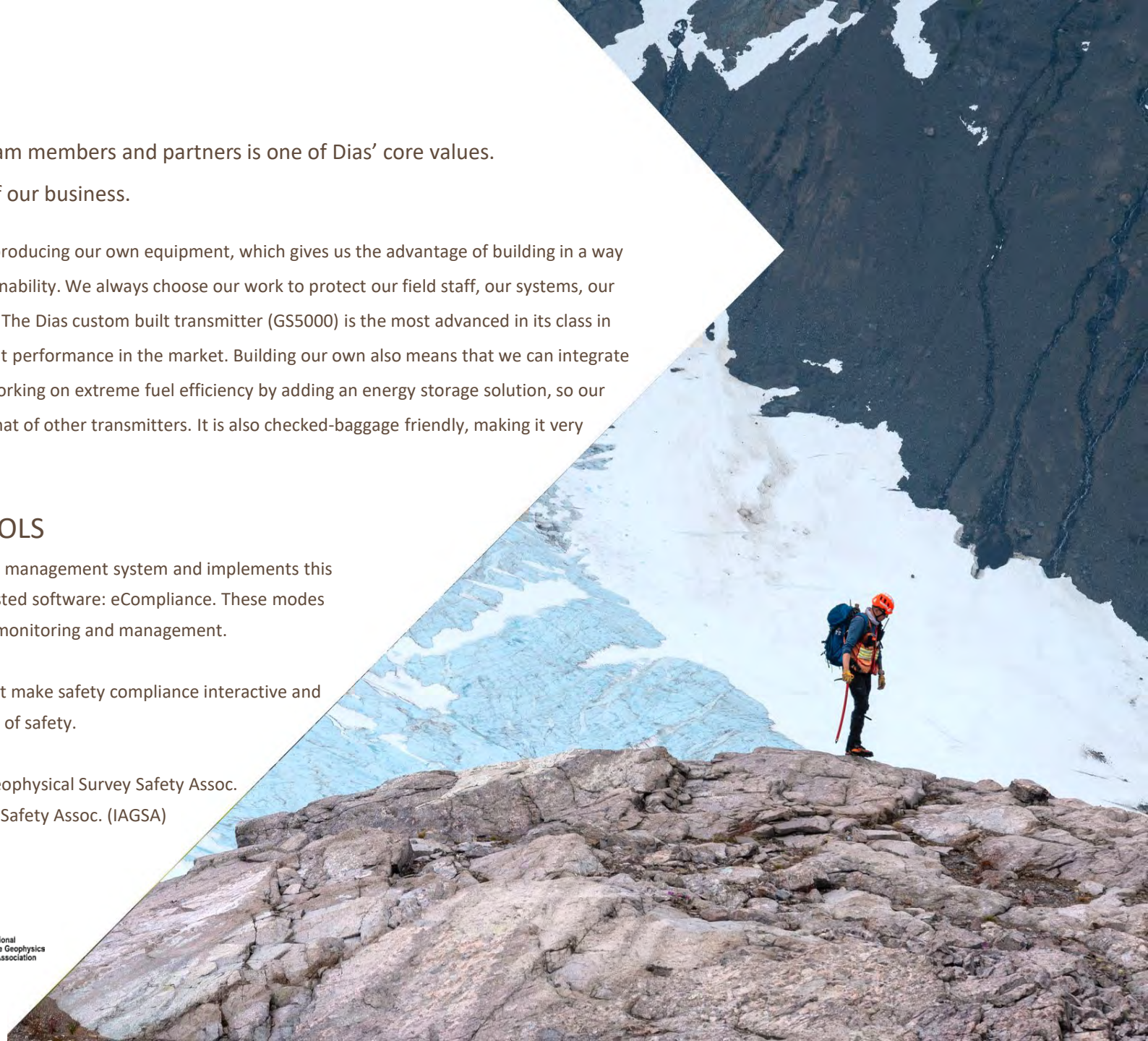

## SAFETY THROUGH OPERATIONAL INNOVATION

Perhaps the most effective way to mitigate risk to our team members is to reduce the number of team members that we deploy on our field teams. Dias' has developed new and innovative system hardware and acquisition methodologies that have optimized our operations to ensure efficient and effective acquisition with a focused team of qualified technical and operational personnel.

## LIGHTNING RISK MITIGATION

The threat of injury or damage from lightning is very real in survey environments and becomes magnified during geophysical surveying requiring deployment of conductive cabling and wire across survey areas. Dias has implemented effective procedures to mitigate this risk and has developed unique patented technologies - critical components of these procedures.

Our lightning shunt technology, DIAS-LS, is proven to effectively reduce or eliminate the propagation of lightning energy along with acquisition cables or wires. Not only does this protect our personnel, but this benefit extends to our operation partners, clients, and our equipment. By protecting our geophysical equipment there is also less risk of downtime due to equipment damage resulting in less time on acquisition programs.

## DIAS GS5000 TRANSMITTER TECHNOLOGY

Dias' GS5000 Transmitter is purpose-designed to reduce electrocution risk to both the operator and the field crew. The transmitter is controlled from a wireless terminal where there are no high voltages present. A fully isolated physical disconnect is still provided to ensure that the crew is not at risk due to transmitter state errors that can occur with high-power contacts and electronics.

## PURPOSE-BUILT SAFETY TECHNOLOGIES

Dias Geophysical's proprietary lightning shunt and current lockout technologies are unique to our industry. In addition to risk mitigation, these purpose-built safety devices provide a tactile and tangible reminder of the importance that we place on safety for our team members.





## GROUND GEOPHYSICS

RESISTIVITY  
**DIAS32** 3D-DCIP  
PATENTED AND PROPRIETARY  
HIGH POWER 3D DIRECT CURRENT  
RESISTIVITY & INDUCED  
POLARIZATION

DIAS32 is the most capable DCIP surveying system for high-resolution results, deep targeting and challenging terrain. In DCIP surveys, an electrical current is injected into the ground and interacts with conductive and chargeable materials in the subsurface. This resulting voltage distribution is measured by Dias patented nodes at surface across the survey area. These measurements are analyzed and interpreted to infer the 3D distribution of electrically conductive and chargeable materials in the subsurface.

*Used in exploration for a myriad of minerals with high success even in challenging terrain.*

*DIAS32 has successfully mapped copper, gold, silver, uranium, cobalt, & more. Discoveries include the Arrow South uranium deposit in Saskatchewan & the Leviathan copper-moly porphyry in Idaho.*



PAGE 10

ELECTROMAGNETICS  
**EM**  
Moving & Fixed Loop  
HT & LT SENSORS  
Dias EM surveys use proprietary **SQUID** (Superconducting Quantum Interference Devices) Technology

**JESSY DEEP** is the world's most sensitive receiver for vector transient electromagnetic (TEM) measurements.

EM detects deeper conductors, 1 km or more with greater precision from increased signal to noise which results in more precise interpretations and better drill targeting.

Dias offers industry-leading high-power transmitters, low-noise receivers, and solutions suitable for deep exploration of conductive ore bodies like copper, nickel, uranium, and gold.

Surveys include SQUIDS, SMARTem24 Receivers and proprietary TM-7 SAM Receivers. These instruments are coupled with high-powered Gap Transmitters.

*Jessy Deep Squid TEM has been effective in detecting VMS, Uranium, and Iron Ore deposits.*



PAGE 18

MAGNETOTELLURICS  
**MT**  
Magnetotelluric surveys image the resistivity distribution in the subsurface by using naturally-occurring electromagnetic signals from solar and atmospheric events as a source.

Its depth of penetration ranges from tens of meters up to tens of kilometers.

The system is designed for the acquisition of MT time series.

*MT surveys have been successful at delineating regional-scale structural features, porphyry Cu deposits, ICG deposits, and imaging the mineral systems that form deposits. AMT surveys provide better resolution than MT*



PAGE 44

ELECTROMAGNETICS  
**HIGH POWER BOREHOLE EM**  
EM/MMR - High-powered, deep search technology produces highest quality downhole data.

Borehole ElectroMagnetics (BHEM) provides greater spatial resolution of closely spaced conductors than surface or airborne geophysical surveys.

BHEM is ideally suited for detecting and characterizing conductive massive sulphide mineralization, like nickel sulphide.

*Used in exploration as for greater spatial resolution of closely spaced conductors.*

*Borehole EM has become an essential tool to better understand drill results and refine follow up drilling. It is responsible for many successes in VMS, Cu, and Iron Ore discoveries.*



PAGE 22

## SEMI AIRBORNE

INDUCTIVE OR GALVANIC SOURCE  
**SUB-AUDIO MAGNETICS (SAM)**

**SAM**  
This proprietary survey technique uses a total field magnetometer at high sample rates to produce low noise EM measurements. SAM surveys use either a transmitter loop, or a grounded bipole source to energize the subsurface. When a grounded bipole is used, the survey delivers Magneto-Metric Conductivity measurements which are excellent at mapping structure to 100s of meters.

SAM surveys are flexible, with several modes, including stationary EM, walking, towed, drone, and helicopter.

*SAM has been the primary technology for many significant discoveries.*



PAGE 44

**HelisAM**  
AIRBORNE EM – HelisAM is used for large dipole (up to 12 km) SAM MMR / MMC surveys and for large scale SAM EM surveys. HelisAM achieves much greater production rates with typical survey speeds of 80 km/h. *HelisAM successfully detected the Lalor VMS deposit that lies 700m – 1000m below surface.*

**SAMSON**  
Surface EM Sub-Audio Magnetics A proprietary method using SAM magnetometer sensor in ground EM deployment where measurements are taken at individual stations. *SAMSON has been successful at detecting VMS & Iron Ore deposits*

**UAV SAM**  
UNMANNED AERIAL VEHICLE UAVSAM refers to semi-airborne acquisition of the SAM geophysical technique, using an Unmanned Aerial Vehicle (UAV). UAVSAM is used commercially for SAM MMR/MMC surveys, SAM Fixed-Loop EM surveys, and SAM Moving Loop EM surveys that require a low impact or are complicated by ground hazards. *UAVSAM can increase the data density of traditional EM surveys while reducing time spent during data acquisition in areas of rough terrain.*

## AIRBORNE GEOPHYSICS

FULL-TENSOR MAGNETIC GRADIOMETRY (FTMG)  
**QMAG<sup>T</sup>**  
This exclusive helicopter-borne survey system measures the magnetic field in detail. The SQUID sensor measures the complete gradient tensor of the earth's magnetic field (FTMG). This measurement provides 6 unique tensor components of the magnetic field which cannot be derived from total field sensors even in gradient setups. The additional information is critical in understanding complex geology and in situations where there is significant magnetic remanence.

*QMAG<sup>T</sup> may be used in exploration for accurate large area data collection where geography or conditions are challenging.*

*The drill program demonstrated the QMAG<sup>T</sup> magnetic survey mapped both stratigraphy and structure related to the LCT pegmatite targets.*



PAGE 28

AIRBORNE PASSIVE-SOURCE EM  
**QAMT**  
Advanced Helicopter Passive MT This exclusive lightweight, airborne magnetotelluric system delivers deep search, high resolution data. Utilizing low-noise JESSY DEEP SQUID sensors, the QAMT system measures natural electromagnetic fields from atmospheric and solar activity. A lightweight towed bird with an advanced motion compensation system allows for precision vector measurements. A full-tensor base station provides a reference and allows for advanced processing. Simultaneous 3 component mag datasets are compared to produce Tipper and apparent resistivity models.

*Used in exploration for rapid mapping of conductive structures at depths of nearly 1km.*

# BEST IN CLASS, INNOVATIVE PROPRIETARY DIAS32 TECHNOLOGY

## 3D INDUCED POLARIZATION (IP) & RESISTIVITY SURVEYS

A ground-breaking IP and resistivity system for high resolution and deep search 3D surveying.

A fully distributed DCIP system using a common voltage reference system and wireless mesh communications for telemetry.

- Proprietary safety technology and procedures assure a safer work environment.
- Mesh network technology provides real-time monitoring of system health and data quality.
- Injection point monitoring of the current waveform improves data quality.
- Optimized survey methodology produces efficient and effective field operations.
- Multi-dipole processing means better balance between depth of investigation and resolution.
- Efficient and low-cost mobilization - compact receiver design, no network cable, less wire.
- Proprietary signal processing routines produce low-noise final data.
- Fully distributed array architecture allows for full flexibility in survey design.
- Water and Rugged Terrain – efficiency on water or in rugged environments is more feasible than ever.
- Experience – Dias has completed surveys in conditions from desert to swamp, -20°C to +40°C, from flat to mountainous, and barren to forested. We have completed surveys from a 7 m to a 400 m inter-electrode spacing. Our clients are happy to provide a reference for our operational and technical capabilities.

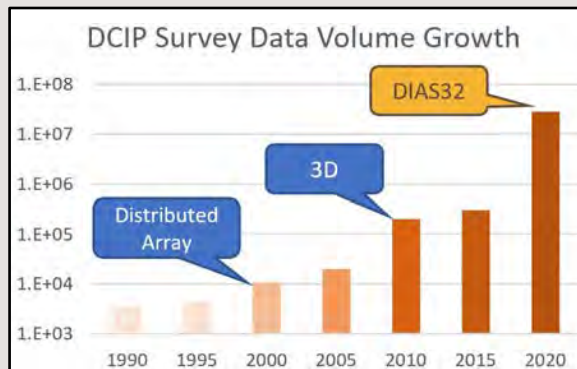

## DIAS32

### GS5000 HIGH PERFORMANCE TRANSMITTER

Dias' GS5000 is the most advanced transmitter technology in its class in the world.

This new transmitter system is fully integrated with our DIAS32 receiver system and our safety technologies.

The GS5000 provides unrivalled power to weight performance with integrated safety features, timing control, and a fully-controlled waveform.

### GS5000 ADVANTAGES

- Delivers top performance in both conductive and resistive ground conditions.
- The GS5000 can be checked onto an aircraft, improving operational flexibility.
- Waveform control produces a high-quality waveform at any base frequency.

### GS5000 FEATURES

- Safety - auto shut-down on fault conditions, remote control
- Current recording, monitoring, and leak detection
- Base performance to 25 kW, 5,000 V, and 20 A
- Full integration with DIAS32 receiver system
- Portable – checked baggage friendly
- Internal GPS time synchronization
- Rugged, portable housing
- -40°C – 50°C



## CVR (Common Voltage Referencing)

enables high-quality multi-scale and multi-azimuth dipole data delivering accurate earth models.

### Main advantages of CVR:

- ✓ **Depth sensitivity** – multi-scale dipoles
- ✓ **High resolution** – multi-azimuth dipoles
- ✓ **Low noise** – common mode noise rejection
- ✓ **Operational efficiency** – less wire, less walking

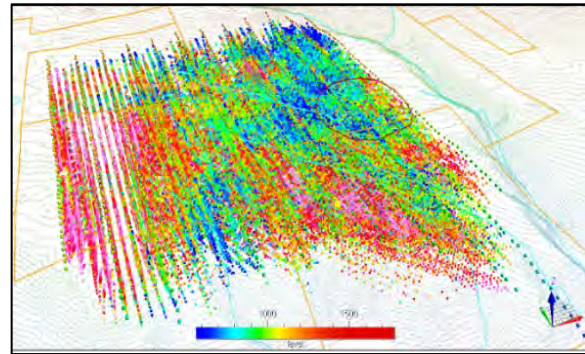

The depth of DIAS<sub>32</sub> 3D surveys is greater with much higher resolution than 2D surveys

In the rolling distributed array 3D resistivity method using CVR, multiple survey lines are surveyed at once. Receivers are deployed along each active line to obtain the resolution necessary to image the subsurface targets. Current injections are carried out between lines or along lines at the midpoint of the adjacent receiver electrodes. For each injection, a measurement is collected at all active receivers, which are later used to calculate dipoles (see below) through integration with our CVR technology. As each line of current injections is completed, the survey is “rolled” until the entire survey area is complete.

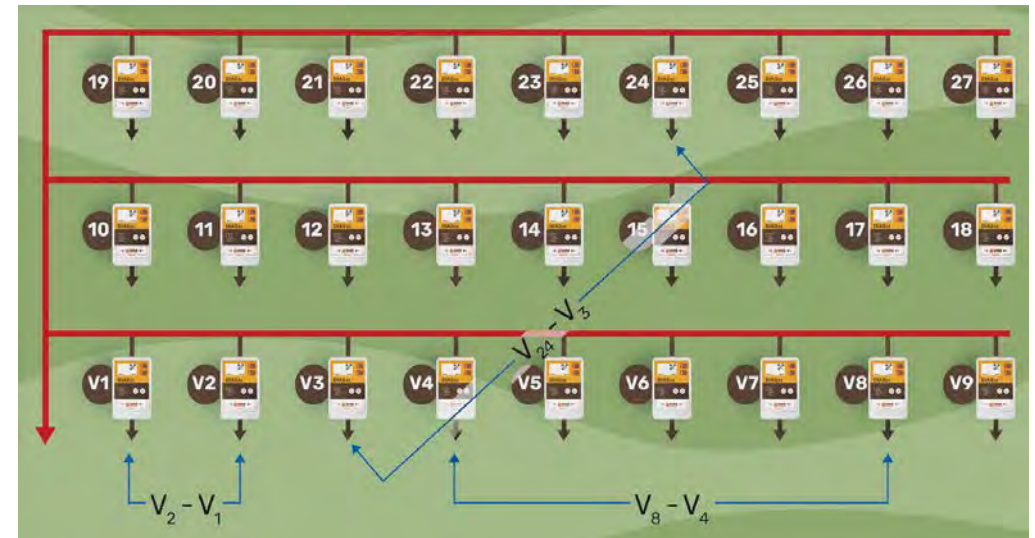

# DIAS32

## SURVEY CHARACTERISTICS

DIAS32 establishes a new standard in 3D IP and resistivity surveying. The patented CVR methodology and wireless mesh network technology deliver unprecedented safety, quality control, and survey flexibility.

### DIAS32 SAFETY

- Designed with safety in mind
- Crew size is optimized - smaller crew means greater overall project safety.
- Lightning shunt and integrated current lockout technologies maximize safety
- Dias' internet-enabled HSE system comprises documentation, training, recording and reporting.

### SURVEYING

- Common voltage reference surveying minimizes wire usage & facilitates acquisition of multiple data sets (p-p & p-d). This mode of surveying also reduces the amount of wire and the associated noise due to EM coupling.
- Each recorder is equipped with GPS positioning and time-synchronization for more accuracy in the modeling of the final results.

### PLANNING

Single-channel architecture allows for full survey design flexibility including gradient, distributed 2D, offset 2D, rolling 3D or full 3D.

### ACQUISITION

The data are acquired as a time series with a sampling rate of up to 200 Hz. A wireless mesh network is established in the survey area for the real-time transmission of data quality and system health information, yielding a more complete, high quality data set.

We acquire pole data at each electrode, measured against the voltage reference wire. Each of these data records can be paired with any other record to build a dipole. This decouples resolution from depth of exploration.

## CONVENTIONAL NON-CVR

UNI DIRECTION  
MONO-SCALE

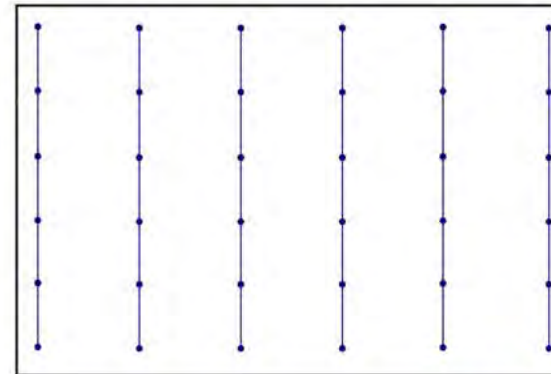

Conventional Non-CVR

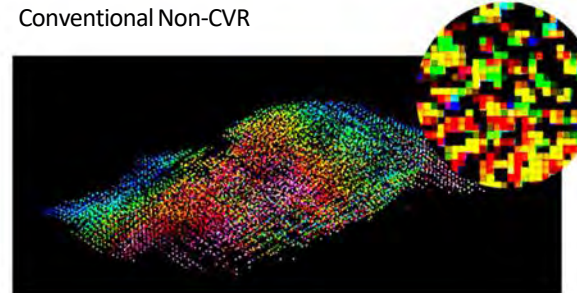

Conventional Non-CVR

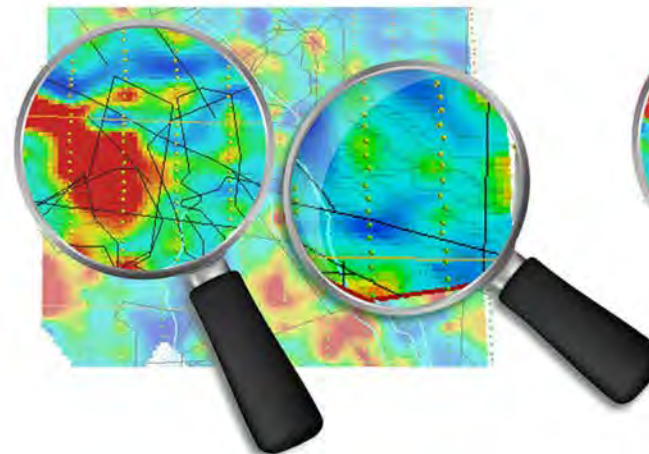

VS

## DIAS32 CVR DIPOLES

DEPTH SENSIVITY – multi-scale dipoles  
HIGH RESOLUTION – multi-azimuth dipoles  
LOW NOISE – common mode noise rejection  
EFFICIENCY – create dipoles across challenging terrain

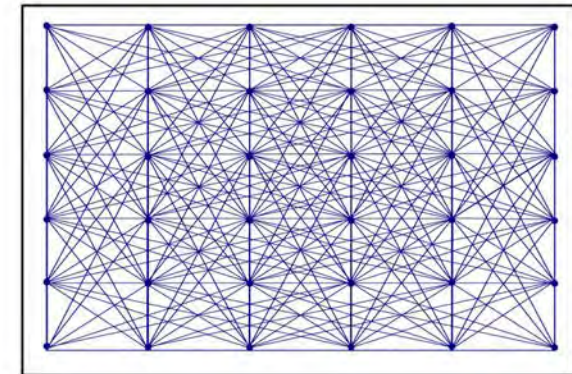

DIAS32 - MORE DATA =  
More accurate, higher resolution models

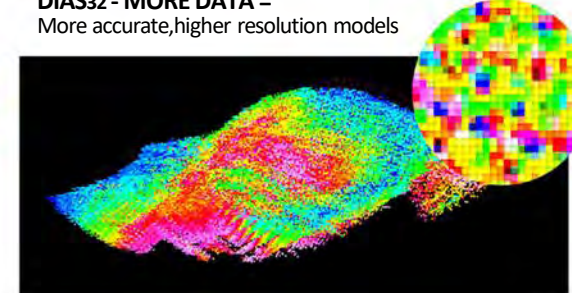

DIAS32 - MORE DATA =  
More accurate, higher resolution models

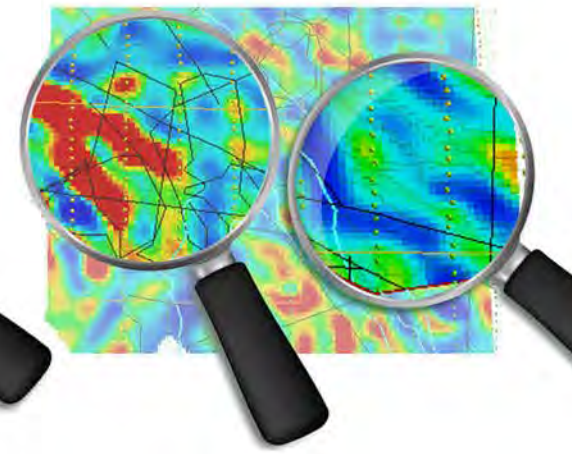

The DIAS32 system architecture allows for complete flexibility in survey design. In the following we describe several effective methods.

### FULL 3D

#### APPLICATION

Where the geology is complex

Where model resolution and accuracy are critical such as in advanced projects or hi-resolution applications

For time monitoring of ground resistivity and chargeability

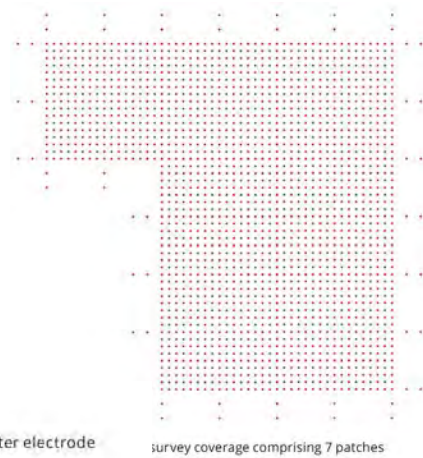

#### FEATURES

- High-density, omni-directional data for accurate 3D models
- Regular orthogonal electrode pattern - no near-surface bias
- Current extensions to enhance coverage at depth near survey margins
- Full scalability – from metre-scale to kilometre-scale surveying
  - multiple ‘patches’ for extensive surveys
- Pole-dipole mode provides a good balance between resolution and depth penetration.
- Optional multi-pole mode adds pole-pole acquisition for greater depth search.

### IRREGULAR 3D

#### APPLICATION

Where access is restricted for safety or other reasons

#### FEATURES

- With single-channel nodes, deployment is efficient and there is no restriction on survey configuration
- GPS location/synchronization in each DIAS32 receiver means each electrode is accurately located – GPS is also recorded at each current injection point
- Survey is planned with safety & efficiency in mind

- Compact, lightweight DIAS32 receivers mean safer and more efficient set-up in challenging terrain
- DIAS32 receivers work in autonomous mode if it is not possible to establish a wireless network
- Common voltage referencing allows full flexibility in dipole selection post-survey

# MAGNETOTELLURICS (MT)

MAGNETOTELLURICS (MT) aims to produce a 3D resistivity model of the ground by recording naturally occurring electric and magnetic fields at the surface. Its depth of penetration ranges from tens of meters up to tens of kilometers.

## OPERATIONAL ADVANTAGES

- Survey designs and optimization using 2D/3D forward modeling and inversion with SimPEG.
- Low-noise MFS07e Metronix Geophysics magnetic induction coil sensors
- A wide array of electrodes are available, from stainless steel for AMT surveys to non-polarizable porous pots for long period MT recordings.
- Low instrumental noise from the receiver.

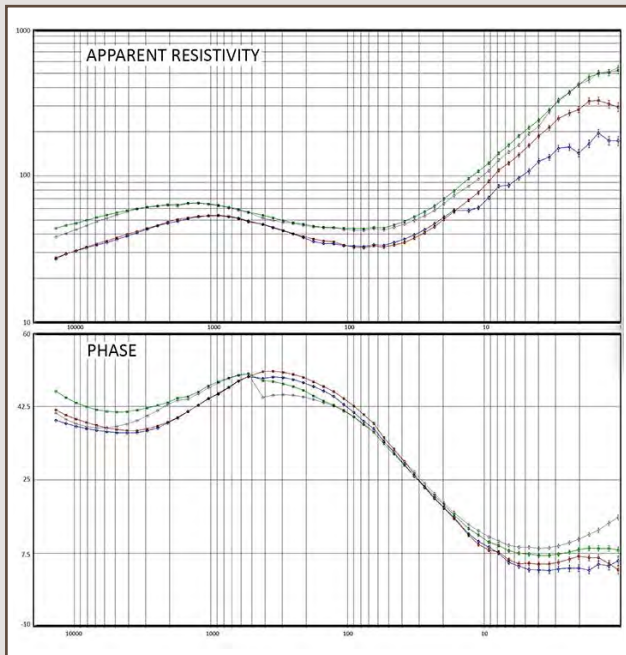

## PRODUCTS

- EDI files – standard in MT community.
- Apparent resistivity maps.
- 2D sections/3D resistivity models
- Orientation information

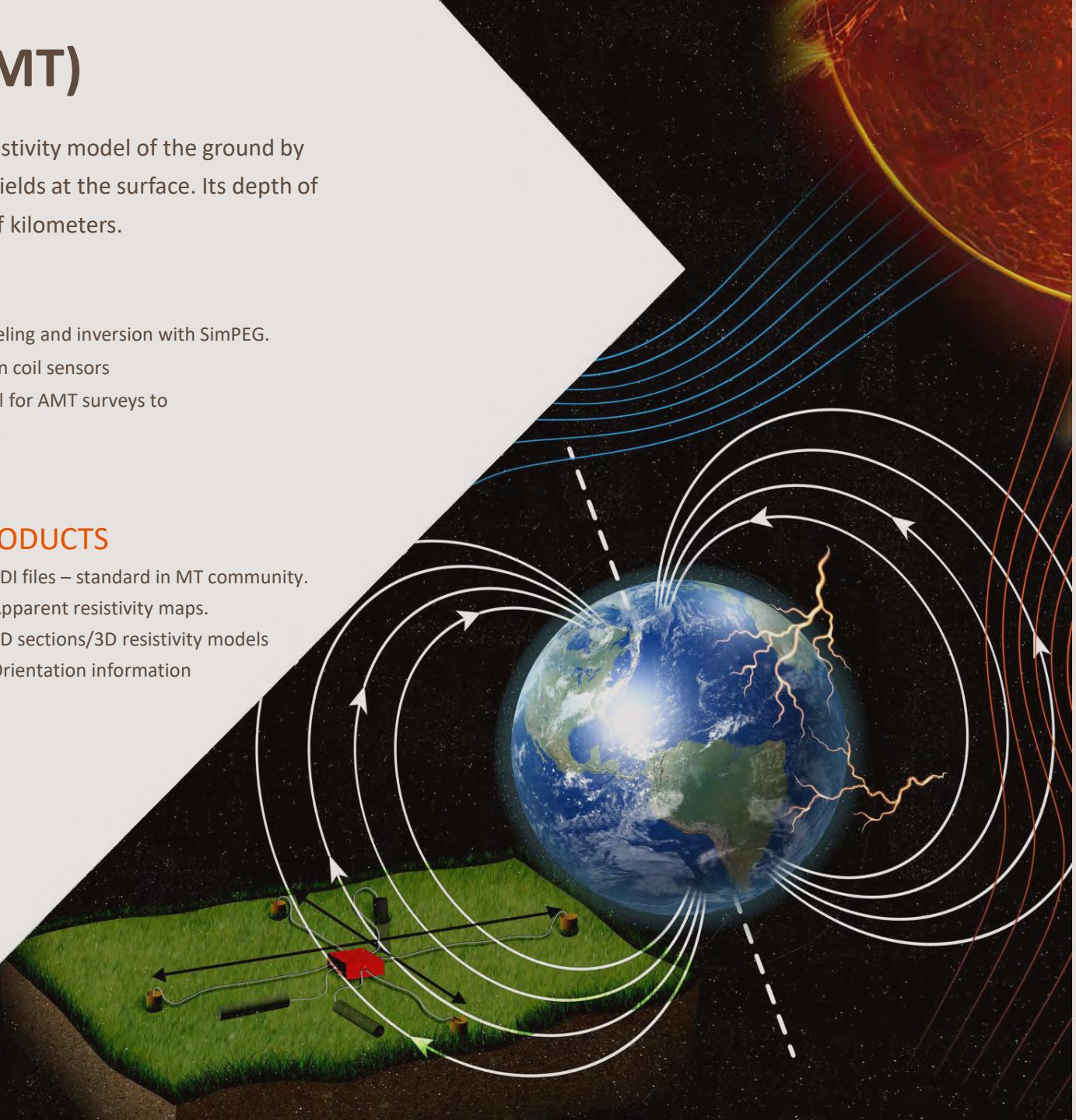

# MAGNETOTELLURICS (MT)

## AUDIO MAGNETOTELLURICS

Audiomagnetotelluric (AMT) surveys use natural electrical energy, primarily from electrical storms that propagate through the atmosphere. AMT surveys are effective in resistivity imaging to depths of up to 1-2 km. The AMT method has seen significant improvement over the last decade, and the method can produce accurate 2D or 3D models for many mineral exploration applications where moderate depth search is required and where resistivity variation is expected.

AMT is the predominant survey method in mineral exploration and as a complement to a DCRES survey

## CONTROLLED-SOURCE AUDIO MAGNETOTELLURICS

Controlled-Source Magnetotellurics (CSAMT) aims to produce a 3D resistivity model of the ground similar to AMT, but through the use of a transmitter site located at a distance from the survey area. The use of a transmitter allows a higher signal-to-noise ratio and a full control on the transmitting waveform.

Several array configurations are available:

- Scalar CSAMT: One transmitter direction, one pair E/H at the station location
- Vector CSAMT: One transmitter direction, two perpendicular pairs E/H at the station location.
- Tensor CSAMT: Two transmitter directions, two perpendicular pairs E/H at the station location.

Transmitter frequencies traditionally range from 5 Hz to 10 kHz.





# MAGNETOTELLURICS (MT)

## PRODUCTS

- EDI files – standard in MT community.
- Apparent resistivity maps.
- 2D sections/3D resistivity models
- Orientation information

## ADU-08e SPECIFICATIONS

- High data quality due to 24/32 Bit Analog/Digital conversion technology
- Can be operated as a stand alone or as a multi-channel network system when connecting multiple ADU-08e in a Local Area Network (LAN, WJ8)
- Automated system self check of ADU-08e and sensors during set up
- Automatic input offset compensation eliminates self potential of electrodes
- Automatic determination of best setup of gains and filters on site
- 12 V battery powered. Only a single battery is required for each ADU incl. sensors
- Compact, lightweight, ruggedized and water-proof instrument design
- Wide operating temperature range from  $-30^{\circ}\text{C}$  to  $+50^{\circ}\text{C}$
- Compatible with all metronix sensors
- Automatic unattended recording mode
- Realtime display of time series and spectral

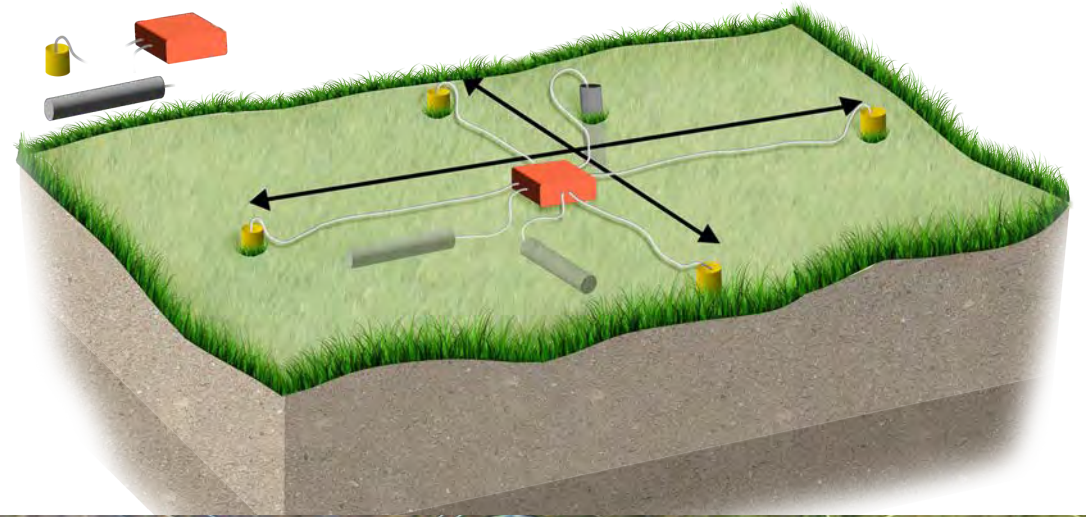

## SURFACE EM – Moving and Fixed Loop

Dias EM surveys use proprietary SQUID (Superconducting Quantum Interference Devices) Technology

JESSY DEEP is the world's most sensitive receiver for vector transient electromagnetic (TEM) measurements.

The general concept of EM is using a source (often a loop of wire, sometimes a dipole) to induce an electromagnetic field in the earth and measuring that response by separating out

the source field (Primary) from the induced field (Secondary)

Transient EM (TEM) is used for locating massive sulfide ore deposits at great depths. Dias' industry-leading high-power transmitters, low-noise receivers, & solutions for deep exploration of conductive ore bodies like copper, nickel, uranium, & gold.

Dias has a history of delivering quality, efficient EM surveys. Surveys include SMARTem24 Receivers and proprietary TM-7 SAM Receivers. These instruments are coupled with high-powered Gap Transmitters to produce data with unprecedented signal/noise ratios.

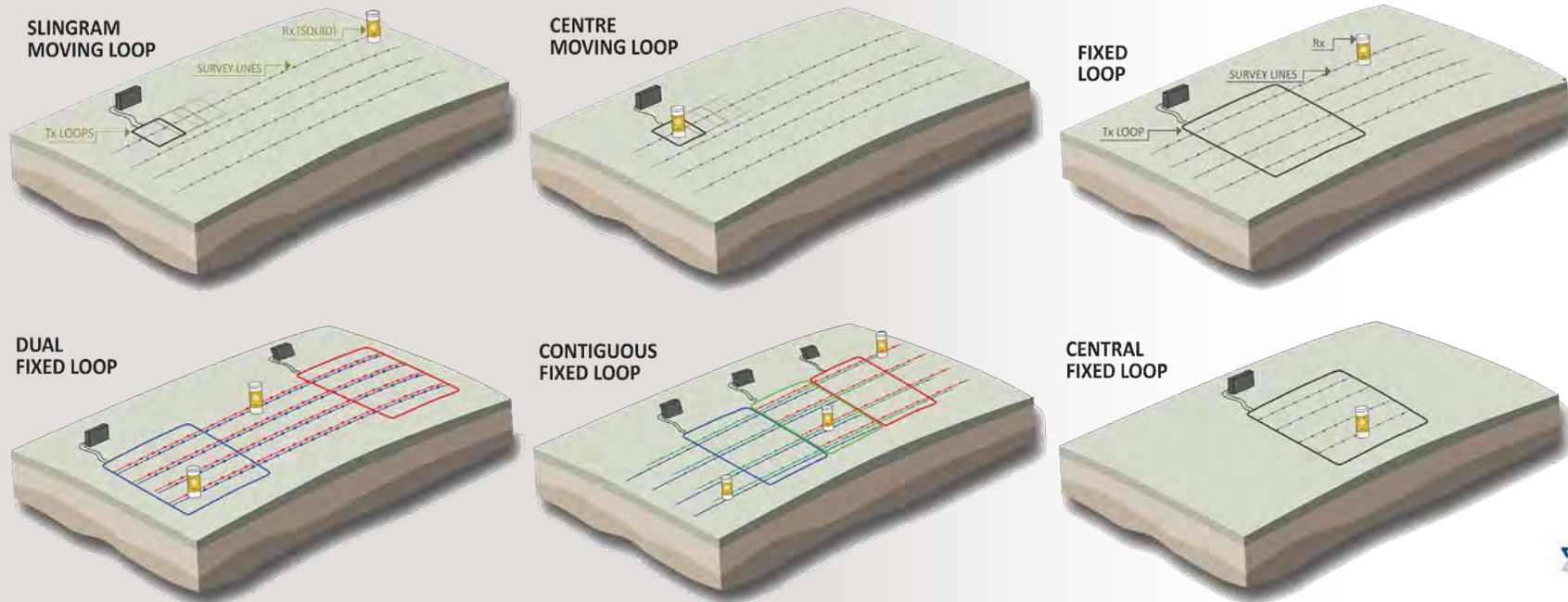

# JESSY DEEP SQUID TEM

## HIGH AND LOW TEMPERATURE SQUID

- Most sensitive TDEM Sensor high and low temperature SQUID
- High temperature cooled with liquid nitrogen; low temperature cooled with liquid helium
- Direct 1C or 3C B-field measurement at low frequency (0.125 to 5.0 Hz)
- Highest signal-to-noise of any TDEM system in the world allowing for unlimited deep minable detection capability
- Enhanced response from good conductors in the presence of weaker conductive formations and overburden
- Unsurpassed sensitivity and coupled with high power transmitters enables superior survey effectiveness



## ADVANTAGES OF SQUID TEM

- Detect deeper conductors
- Greater precision from increased signal to noise results in more precise interpretations and better drill targeting
- Increased discrimination of conductors because of wider bandwidth of B-field response
  - Detect basement conductors under conductive cover
  - Identify individual conductors within a conductive zone
- Increased signal to noise leads to simplified survey logistics ie: smaller transmitter loop, wider station interval

Type	Sensor	Data Type B-Field, dB/dt, Total Field	Typical Base Frequency Range**
SQUID	Supracon High Temp SQUID (HTS)	B-Field	0.25 – 10 Hz
	Supracon Low Temp SQUID (LTS)	B-Field	0.0125 – 10 Hz
Fluxgate	EMIT SMART Fluxgate	B-Field	5 – 30 Hz
Coil's	Geonics 3D-3	dB/dt	10 – 30 Hz
	Monex TRC	dB/dt	
	EMIT Coil	dB/dt	
Borehole Probes	EMIT DigiAtlantis	B-Field	0.25 – 10 Hz
	Geonics BH43-3	dB/dt	10 – 30 Hz
	Monex VECTEM	dB/dt	10 – 30 Hz
	EMIT Coil Probe	dB/dt	
Cesium Vapour	GAP SAM System (SAMSON)	Total Field	0. – 10 Hz
	GAP SAM System (HeliSAM, UAVSAM, SledSAM)	Total Field	5 – 10 Hz

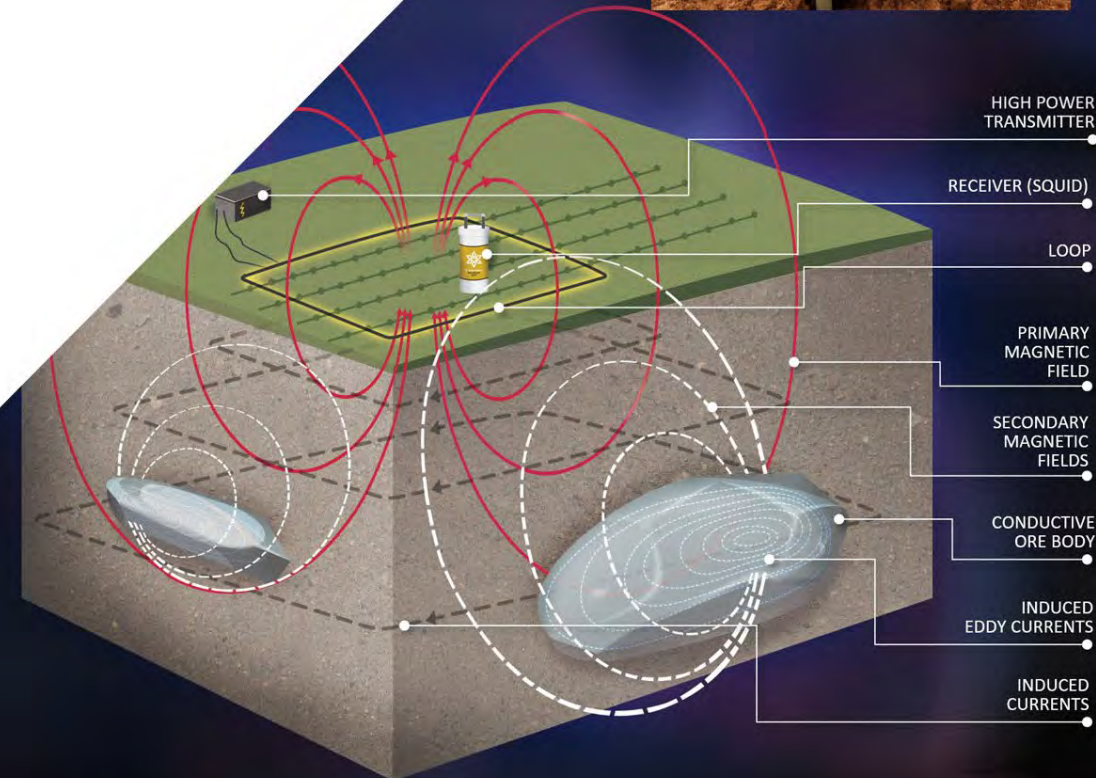

# SURFACE EM SURVEY MODES

## EM SURVEY MODES

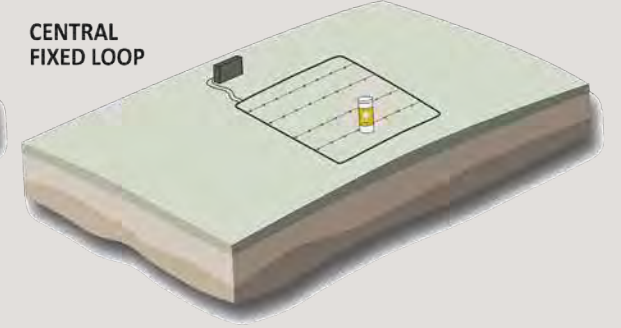
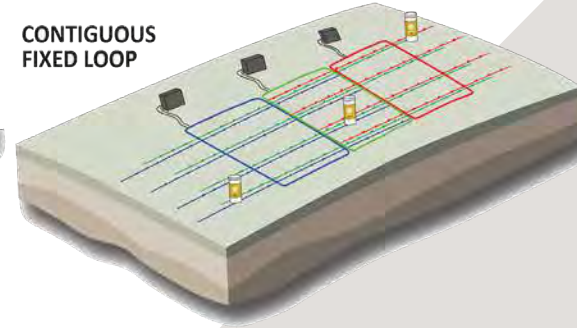
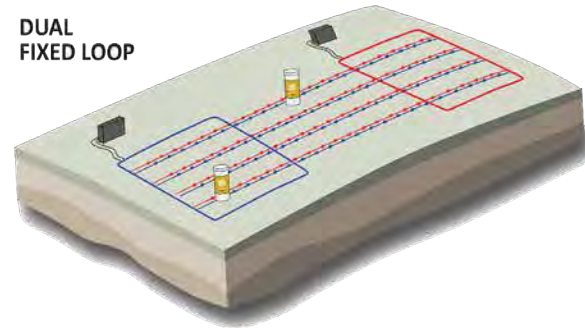
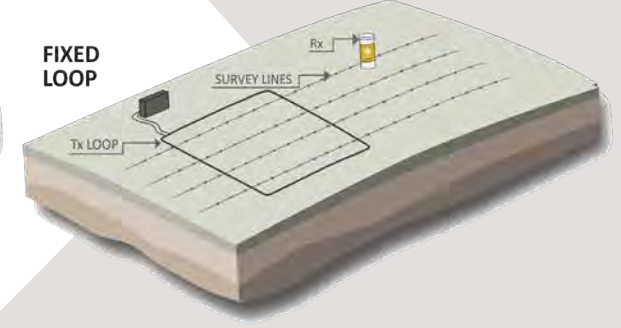
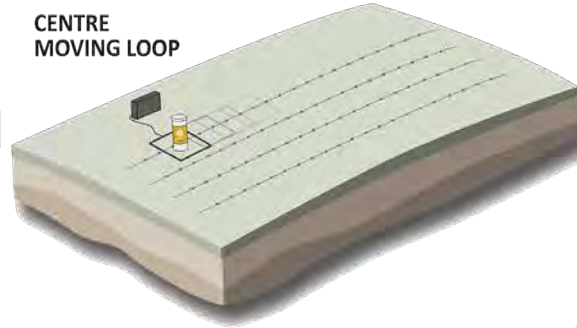
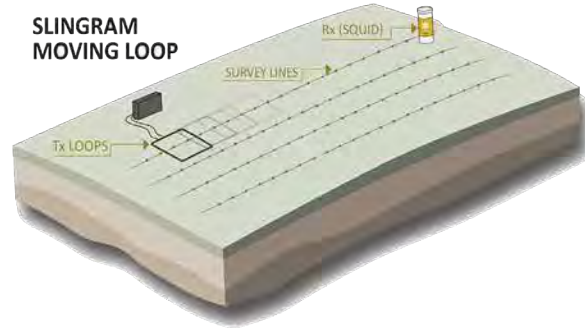

## SQUID vs Coil - SLINGRAM MOVING LOOP

DATA COURTESY OF AREVA  
RESOURCES CANADA INC.

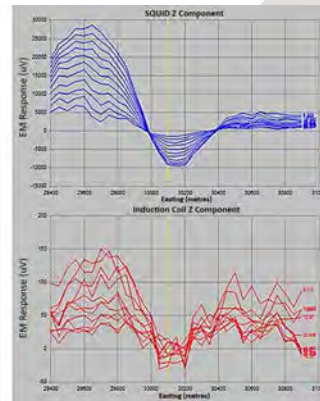
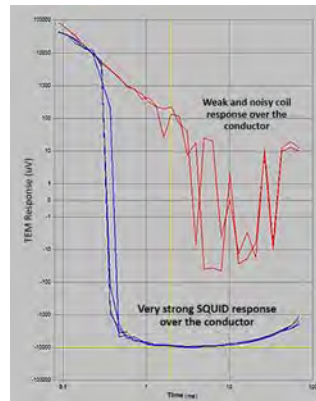

# HIGH POWER BOREHOLE EM

## BOREHOLE EM

Dias' Borehole systems combine Gap High Powered EM Transmitters and DigiAtlantis Probes, resulting in the most powerful downhole EM systems currently available. They are ideally suited to the detection of subtle or deep conductors. \*Gap is a Dias company

### DigiAtlantis SYSTEM

- 3-component Fluxgate B-field sensor
- Simultaneous acquisition of all components
- Calculation of Downhole magnetics and Hole Trajectory
- Real time viewing of data for improved data quality bodies.

### APPLICATIONS

The BHEM technique is ideally suited for detecting conductive massive sulphide mineralization, in particular nickel sulphide bodies.

The Borehole Magneto Metric Resistivity (BHMMR) technique is ideally suited for detecting narrow ribbon shaped and/or poorly conducting mineralization such as sphalerite rich bodies.



# HIGH POWER BOREHOLE EM

- B-Field data – emphasizes good conductors.
- Capable of lower transmitter frequencies and later time channels.
- Simultaneous full waveform acquisition (A,U,V).
- SMART digital signal processing – superior rejection of power line, sferic, and telluric noise
- Also measures accurate hole trajectory trace (dip, azimuth), along with 3-component magnetic data.
- Probe Dimensions 2280mm x 33mm (fits BQ drill bit, PVC lining).
- Presently operational to a 2km vertical depth.

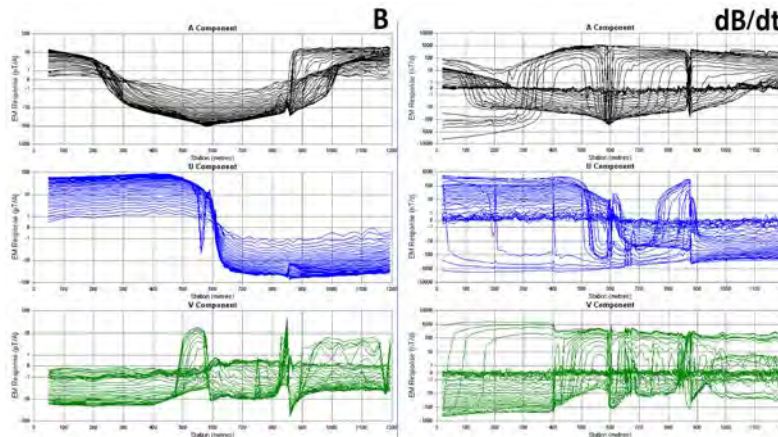

Logarithmic scale profiles of all windows of DigiAtlantis B-field 1 Hz (left) and coil dB/dt data 1.67 Hz (right).

## SPECIFICATIONS

Sensors	3-component fluxgate (EMIT DigiAtlantis) or 3-component coil (Geonics BH43-3)
Winches	AusLog 600-4 (600m), AusLog 2000-4 (2000m) or DGRT Laminar (2000m)
Tx Synchronization	GPS 1PPS pulse or clock
Transmitters	Gap HPTX-80/80 Transmitters
Base Frequency	Typically 0.125Hz to 2.0Hz
Current	200A for a 600m x 600m loop 140A for a 1000m x 1000m loop, using 35 sq mm wire
Receiver	EMIT DigiAtlantis



# DIAS<sub>EM</sub> HIGH POWER IN-MINE BOREHOLE EM

## HIGH-POWER IN-MINE BOREHOLE ELECTROMAGNETIC SYSTEM

deploys a unique high-power transmission system for increased signal to noise.

This system explores a much larger volume around each drill hole, for much more efficient in-mine exploration.

## DIAS<sub>EM</sub> IN-MINE BHEM

- Highest power solution available
- Tx loop deployed in workings
- Selection of receiver probes

While the high-power TerraTx-200 system is transmitting, boreholes within and adjacent to the mine can be surveyed to detect conductive sources.

Compatible with standard B-field or dB/dt borehole EM probes, such as EMIT Digi-Atlantis, Monex Geoscope Vectem V, and Geonics 3D.

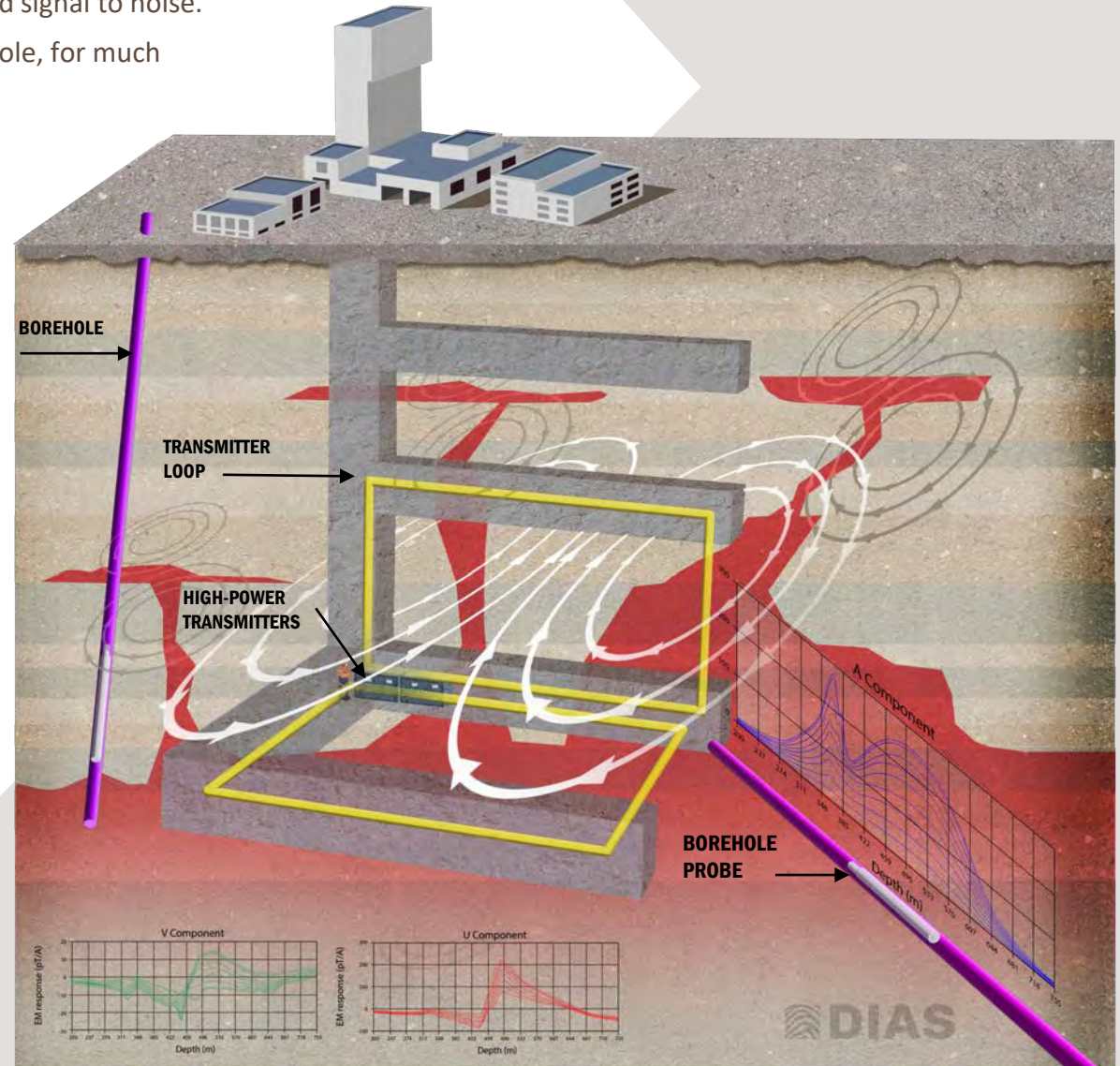



## Deliverables Summary

- Maxwell TEM Files
- Logistics Report
- PDF Profile Plots
- Borehole log image

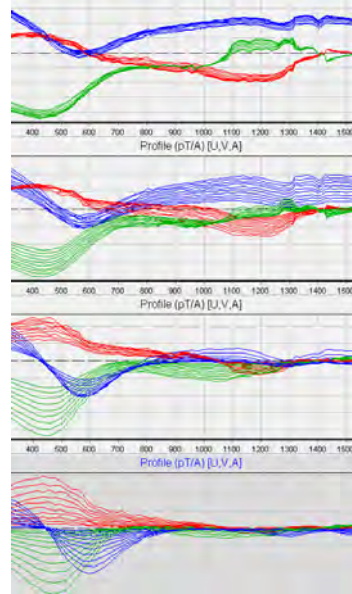

## TerraTx-200 TRANSMITTER SPECIFICATIONS

- DC Loop Input: 4 V to 350 V
- Can synchronize up to 4 units for enhanced performance
- Maximum output current: 200 A per unit
- Waveform: bipolar square wave, 50% to 100% duty cycle
- Maximum power: 30 kW per unit
- Inbuilt protection: overload and earth leakage
- Active monitoring: loop input voltage, loop current, temperature, and over-current
- Cooling: glycol-water
- Operating temperature: -20 to + 50 degrees C
- Console dimensions: 48 cm (W) × 68 cm (D) × 13.3 cm (H)
- Console weight: 56 kg
- Power source: mains



Four TerraTX-200 transmitters paired with 160 V / 188 A rectifiers, operating at 480 V.



# HeliWINDER

## UNIQUE TECHNOLOGY INNOVATION

Our innovative HeliWinder™ Technology, can lay 10 km = 1500 lbs of wire in just 1 HOUR.

No more carrying heavy spools in rugged terrain for days.

- Rapid loop deployment
- Rapid loop retrieval
- No line cutting required
- Easily utilized in rough terrains
- Accurate GPS geo-referencing
- Up to 10 km deployed per hour
- Reduced injury potential
- Built-in remote wire cutter
- Automatic brake system

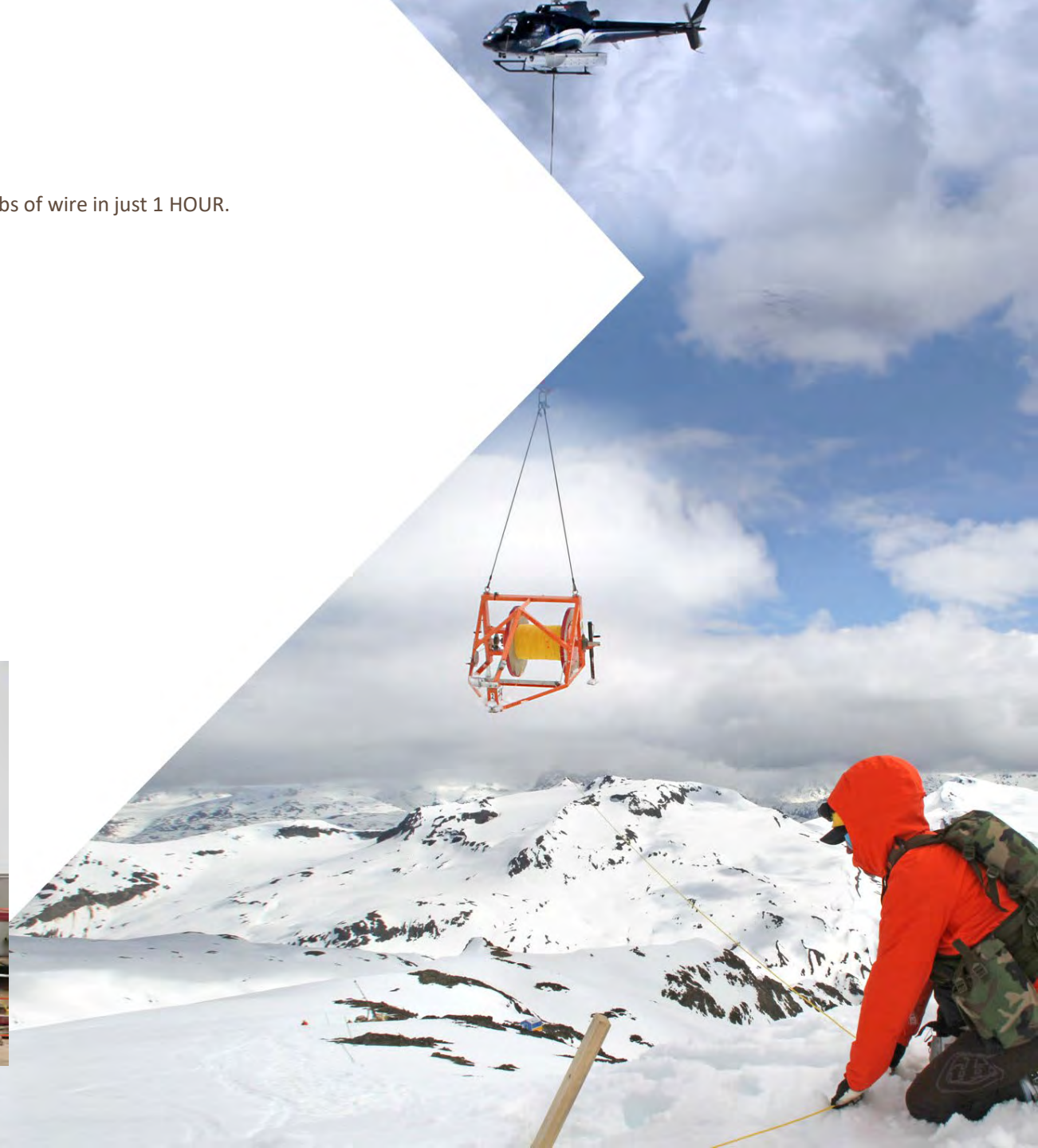

# LEADING THE INDUSTRY IN AIRBORNE GEOPHYSICS

Dias' airborne expertise includes highly effective technologies using SQUID-based sensors in partnership with Supracon AG of Germany (SQUID - superconducting quantum interference detectors).

- Measure magnetic field with incredible accuracy and resolution
- Measure directional information that other magnetic system cannot measure
- Produce more accurate and higher resolution models for our clients
- Dias has flown these system for exploration of nickel, iron ore, lithium, and copper.
- As a lightweight system, QMAG<sup>T</sup> can be deployed in most operating environments.
- QMAG<sup>T</sup> system is deployed in a custom-built airfoil beneath a helicopter.
- Sensors measure the magnetic field with unrivaled sensitivity.



QMAG<sup>T</sup>

AIRBORNE FULL-TENSOR MAGNETIC  
GRADIOMETRY (FTMG)

27



# QMAG<sup>T</sup>

AIRBORNE FULL-TENSOR MAGNETIC GRADIOMETRY (FTMG)

UNRIVALLED AIRBORNE MAGNETOMETRY



# QMAG<sup>T</sup>

## AIRBORNE FULL-TENSOR MAGNETIC GRADIOMETRY (FTMG)

### UNRIVALLED AIRBORNE MAGNETOMETRY

The QMAG<sup>T</sup> system is a helicopter-borne magnetic survey system that measures the magnetic field in a robust and detailed manner. The SQUID (superconducting quantum interference device) sensor measures the complete gradient tensor (second-order) of the earth's magnetic field (otherwise known as full tensor magnetic gradiometry – FTMG). This FTMG measurement provides directional information about the magnetic field which is not available from total field sensors, which have been the industry standard for many years.

The SQUID sensors are developed by Supracon AG of Jena, Germany. Operating within a liquid helium bath, the sensors measure the magnetic field with unrivaled sensitivity. The sensor system is the result of over 20 years of development and testing and has flown many successful exploration campaigns. The QMAG<sup>T</sup> system is the full commercialization of this established system.

The QMAG<sup>T</sup> system is deployed in a custom-built airfoil beneath a helicopter. This 'bird' effectively reduces motion noise, allowing for the recovery of high-quality data. As a lightweight system, QMAG<sup>T</sup> can be deployed in most operating environments.



*Dias Airborne is a partnership between Dias Geophysical of Saskatoon, Canada, and Supracon AG of Jena, Germany. Dias Airborne offers QMAG<sup>T</sup> and QAMT surveys.*



# QMAG<sup>T</sup>

## AIRBORNE FULL-TENSOR MAGNETIC GRADIOMETRY (FTMG)

### QMAG<sup>T</sup> ADVANTAGES

- Plug and play helicopter operation for acquisition in most environments.
- Direct determination of anomaly geometry, irrespective of whether the source is remanent or induced.
- Better information on magnetization directions. The magnetic moment of compact sources can be directly determined.
- Gradient measurements, particularly full tensor measurements, determine on which side of a survey line a source lies.
- Effective survey results in low latitude environments
- Redundant tensor components (4 of the 9 measured tensors are redundant) give inherent error correction and noise estimates.
- Desirable mathematical properties, allowing magnetization mapping, rigorous continuation, reduction to the pole, depth slicing, invariants, etc.

*The QMAG<sup>T</sup> technology will take magnetic mapping and interpretation to the next level.*

*After over 50 years of measuring and interpreting the total magnetic field, the QMAG<sup>T</sup> system will improve the interpretation of target location, geometry, orientation, and magnetization.*

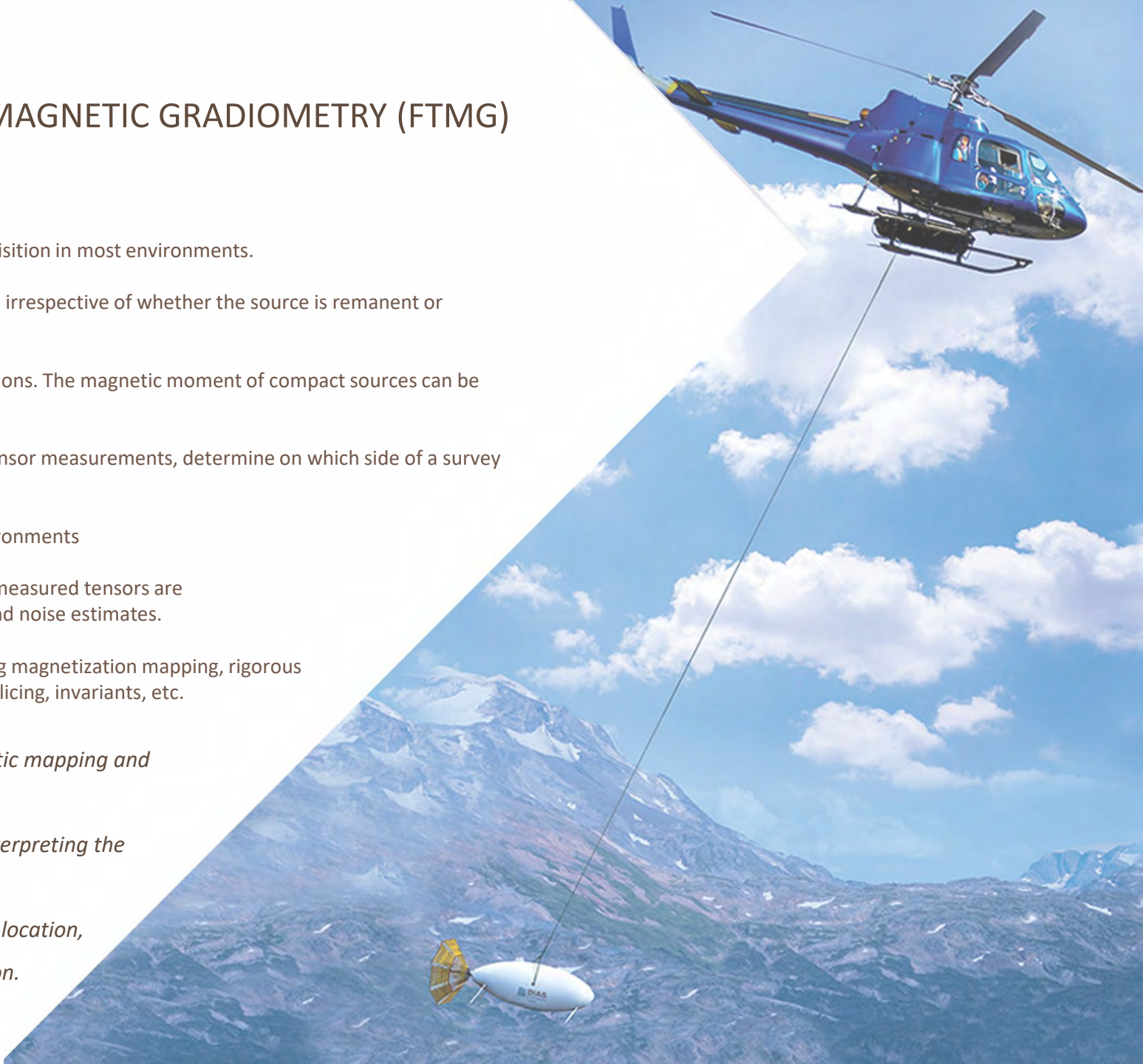

# QMAG<sup>T</sup>

## AIRBORNE FULL-TENSOR MAGNETIC GRADIOMETRY (FTMG)

### THE MOST ADVANCED HELICOPTER MAGNETIC SYSTEM

The product of 24 years of R&D, the QMAG<sup>T</sup> technology has a long track record of successful application throughout the world.

#### QMAG<sup>T</sup> SYSTEM SPECIFICATIONS

SQUID Sensor:	6 channels first order planar gradiometers
Intrinsic Gradient Noise:	<100 fT / (mVHz)
Magnetometer:	4 channels of magnetometers
Intrinsic Noise:	2 pT / √Hz
SQUID Electronic Bandwidth:	> 3 MHz
Operating Temperature Range:	-10°C to +40°C
Cryostat Operation:	2.5 days after refill
Data Acquisition:	20 channels of 24 bit ADCs
IMU System:	3 fibre optic gyros, 3 accelerometers
Radar Altimeter:	Max of 3% or 0.5 m
Laser Altimeter:	+/- 1 to 2 cm typical
Total Bird Weight:	267 kg
Tow Rope:	Dyneema <sup>TM</sup> - 32+ m



THE GRADIENT TENSOR  
IS A  $3 \times 3$  SECOND-ORDER  
TENSOR.

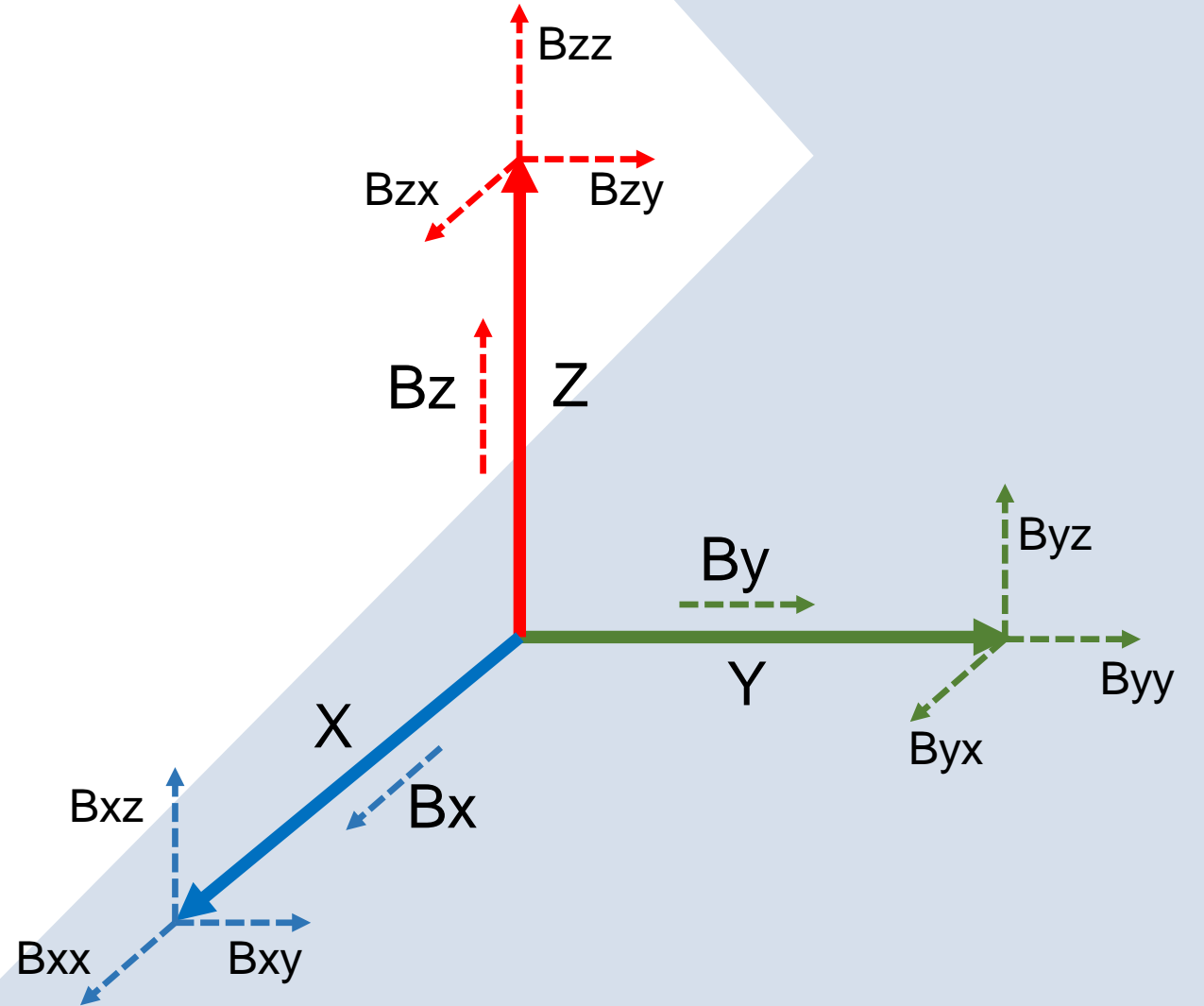



# QMAG<sup>T</sup>

## AIRBORNE FULL-TENSOR MAGNETIC GRADIOMETRY (FTMG)

### CRYOGENIC – LIQUID HELIUM

SQUID sensor systems have  
revolutionized ground EM surveying –  
we expect the same advantages will be  
seen in airborne applications

The QMAG<sup>T</sup> system can be combined  
with radiometric data acquisition for  
multi-parameter surveying



THE GRADIENT  
TENSOR FOR A  
MAGNETIC CUBE.

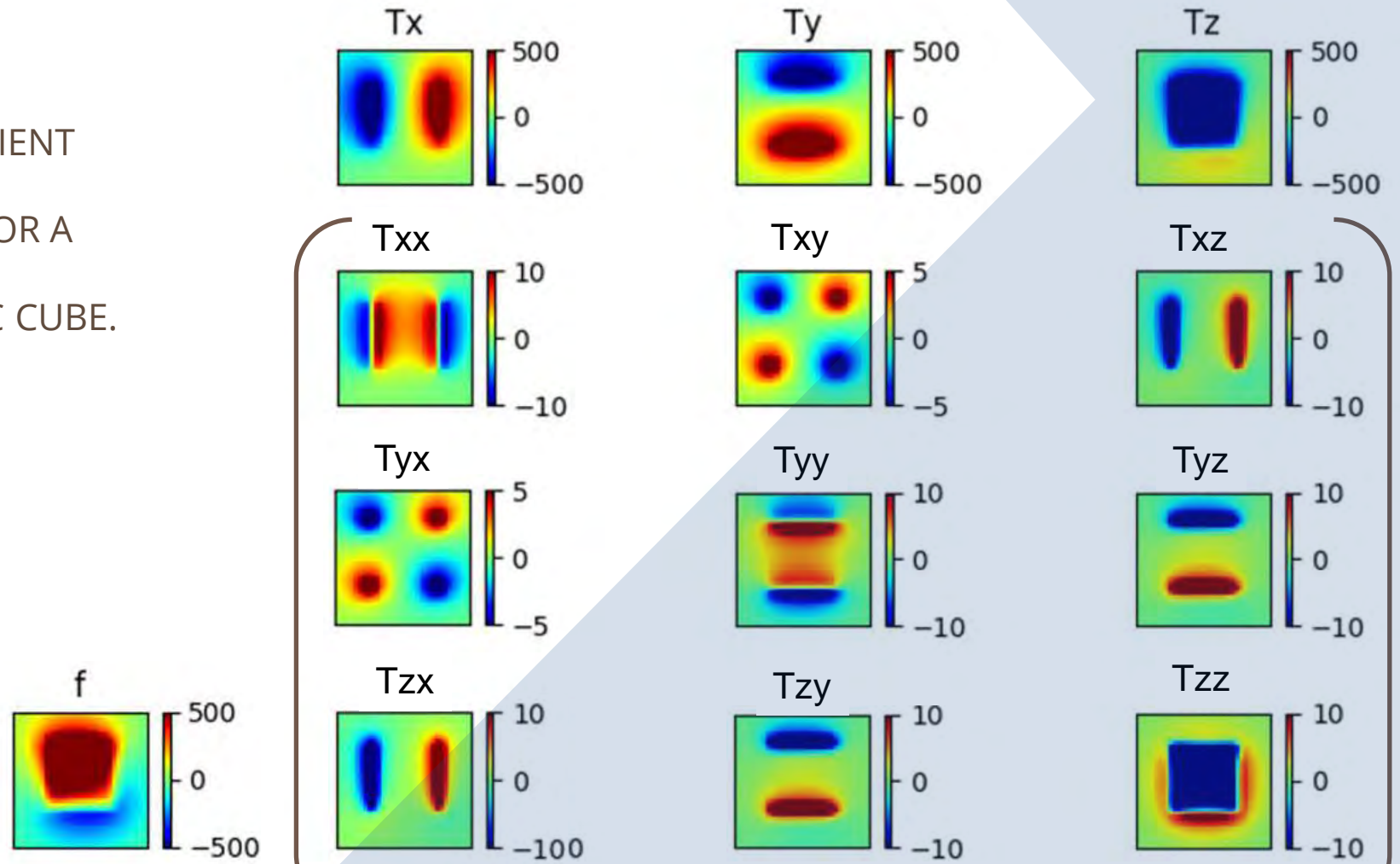

Cole and Cooper, 2017

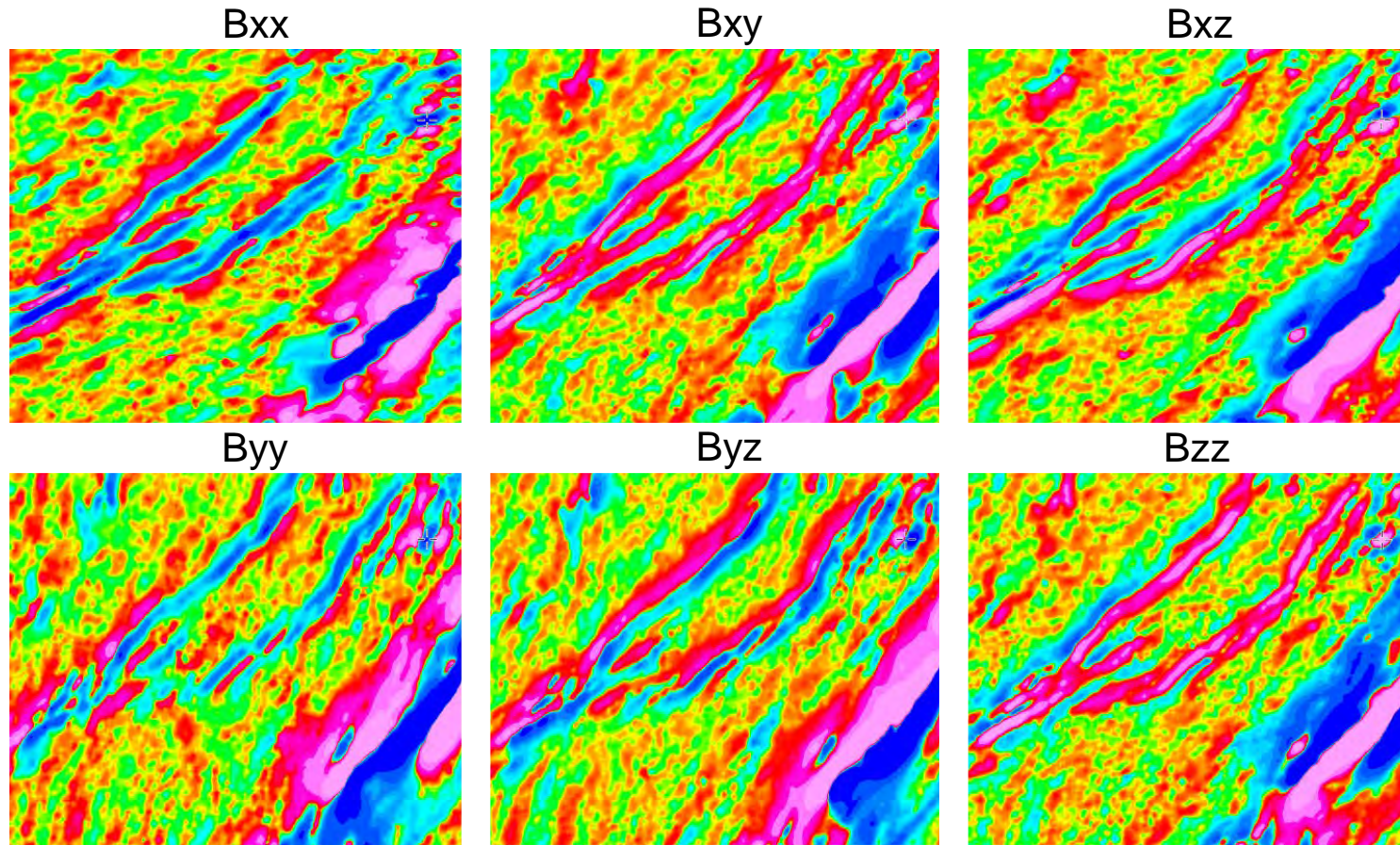
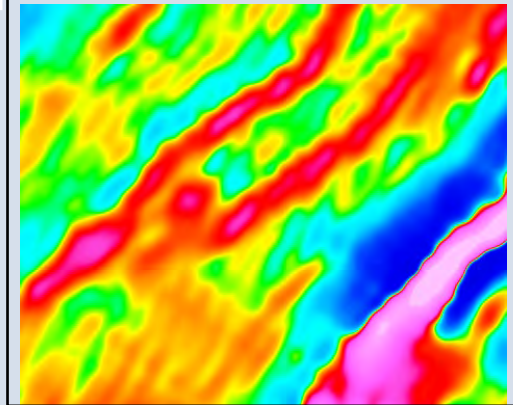

## DIAS FULL TENSOR GRADIENT MAGNETICS

STANDARD  
HELIBORNE  
MAGNETICS

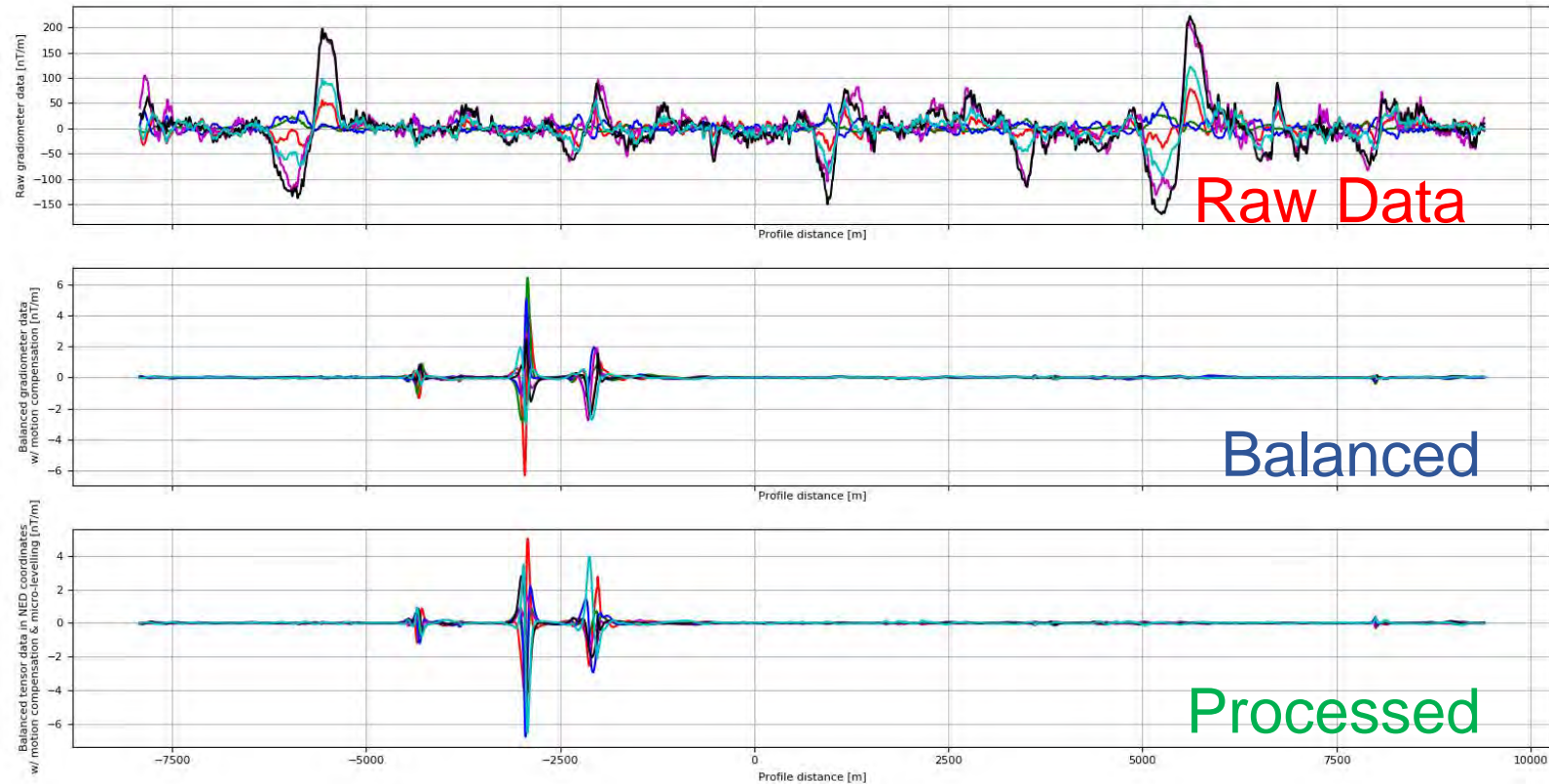
QMAG<sup>T</sup> PROCESSING

**QMAG<sup>T</sup> APPLICATIONS**

Kimberlite mapping and characterization

Ultramafic intrusion related mineralization

Complex geology/structural gold

Iron ore environments

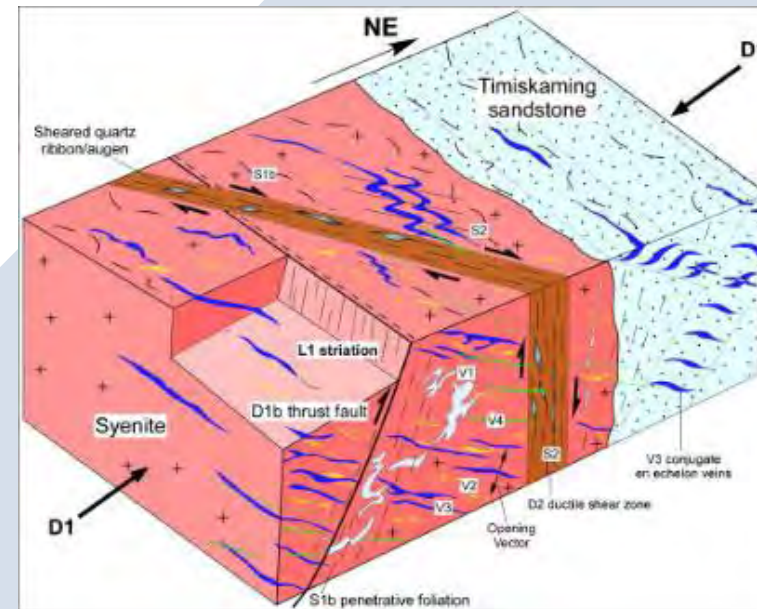
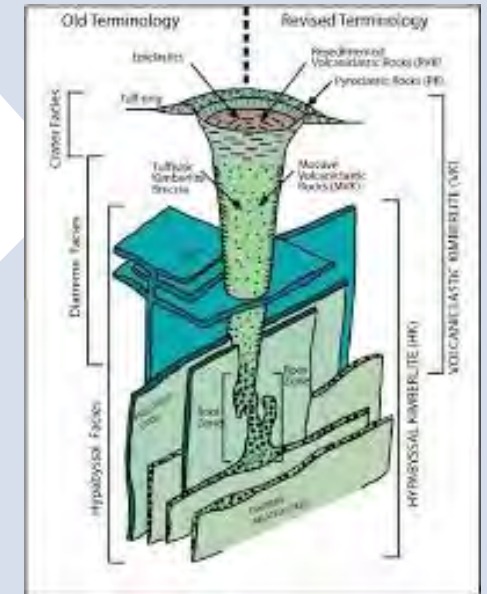
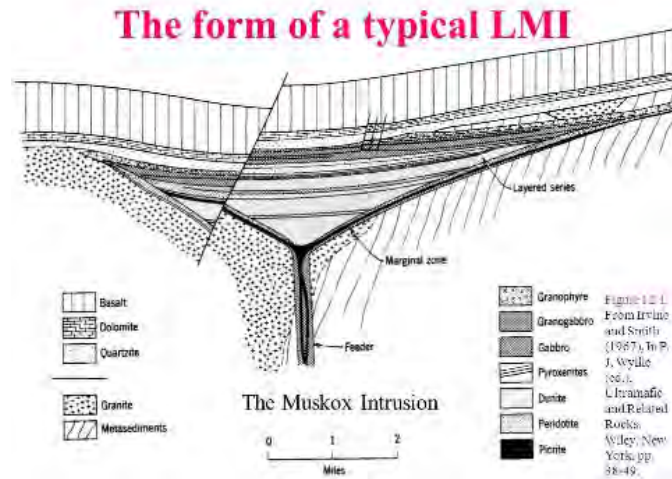

Example of a recent survey where we are mapping in a Canadian Shield environment with mafic and felsic units, intrusions, and plenty of breaks and folding. We can see the ability to image geologic contacts with high resolution, faults and breaks with confidence, subtle northeast and southeast trends, and clear remanently magnetized sources.

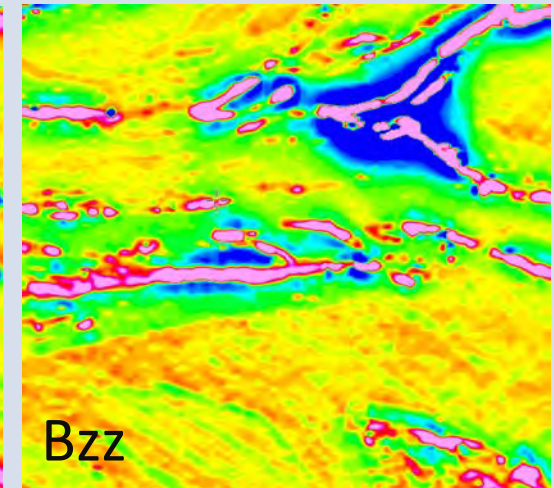
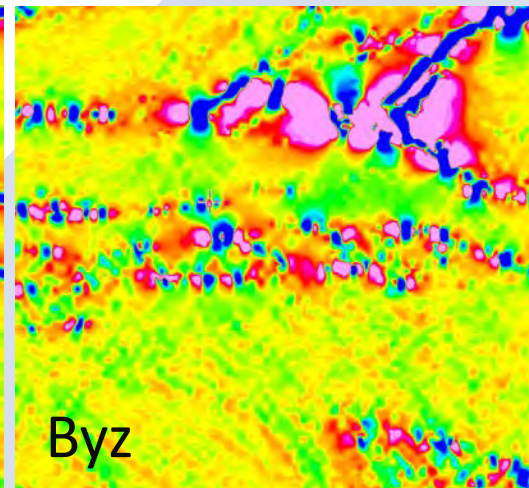
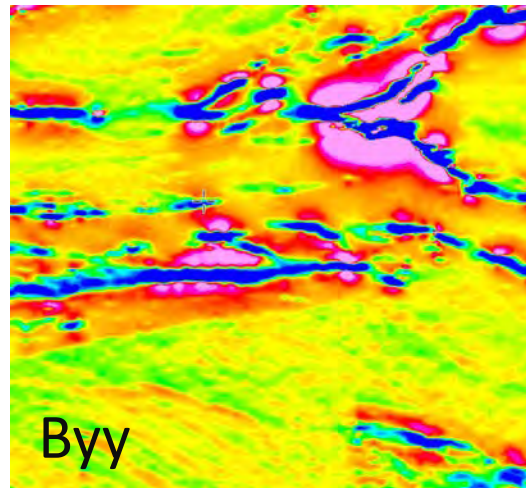
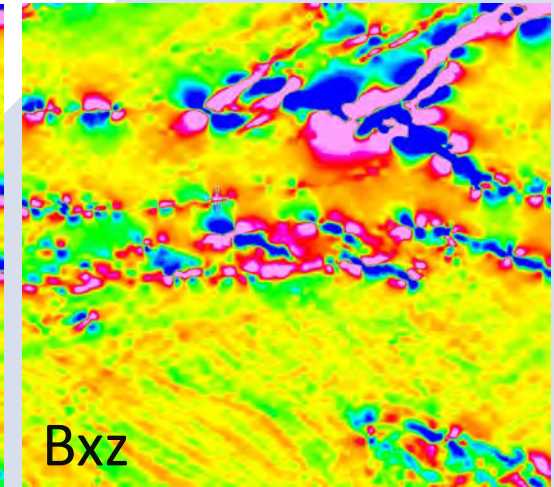
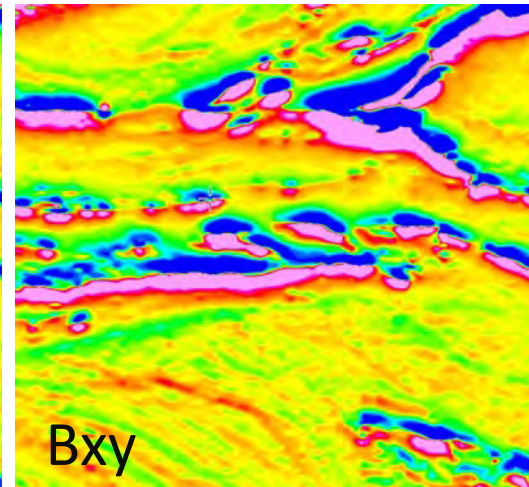
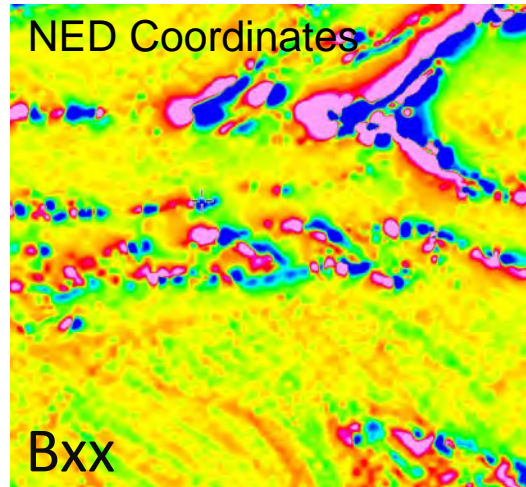

QMAG<sup>T</sup> BENEFITS

## RESOLUTION AND DETECTABILITY

- extremely low-noise FTMG measurements ( $<10\text{pT}_{\text{RMS}}/\text{m}$ )
- the benefits of vector surveys without the disadvantage of extreme sensitivity to orientation
- higher spatial resolution ( $\sim 2\text{X}$ ) (Rasmussen & Pedersen, 1990)

## REMANENCE MAPPING

## LOW LATITUDE SURVEYS

## IMPROVED GEOLOGIC MODELLING

- Reduces non-uniqueness of potential fields
- Better model results, accurate, detailed 3D models

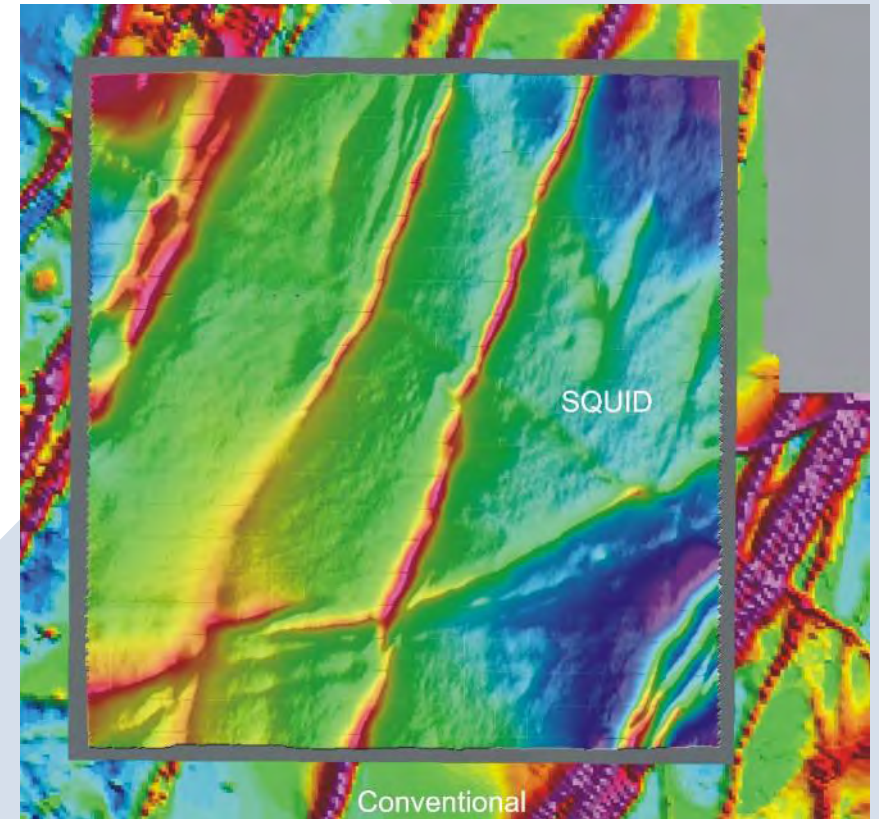

$G_{ZZ}$  image -  $7 \times 7 \text{ km}^2$  (960 km)  
courtesy Anglo Platinum

### 3D Inversion

#### Input Data

- Bxx, Bxy, Bxz, Byy, Byz, Bzz
- Total Field

#### Output Data

- Magnetic Susceptibility
- Remanence
- Field Vector

### Final Inversion Details

- Data every 25 m along line
- Total Data = 48,307
- Mesh - 6.25 x 6.25 x 6.25 m
- Total Cells = 2,459,808 cells
- RAM Usage = 540 Gb

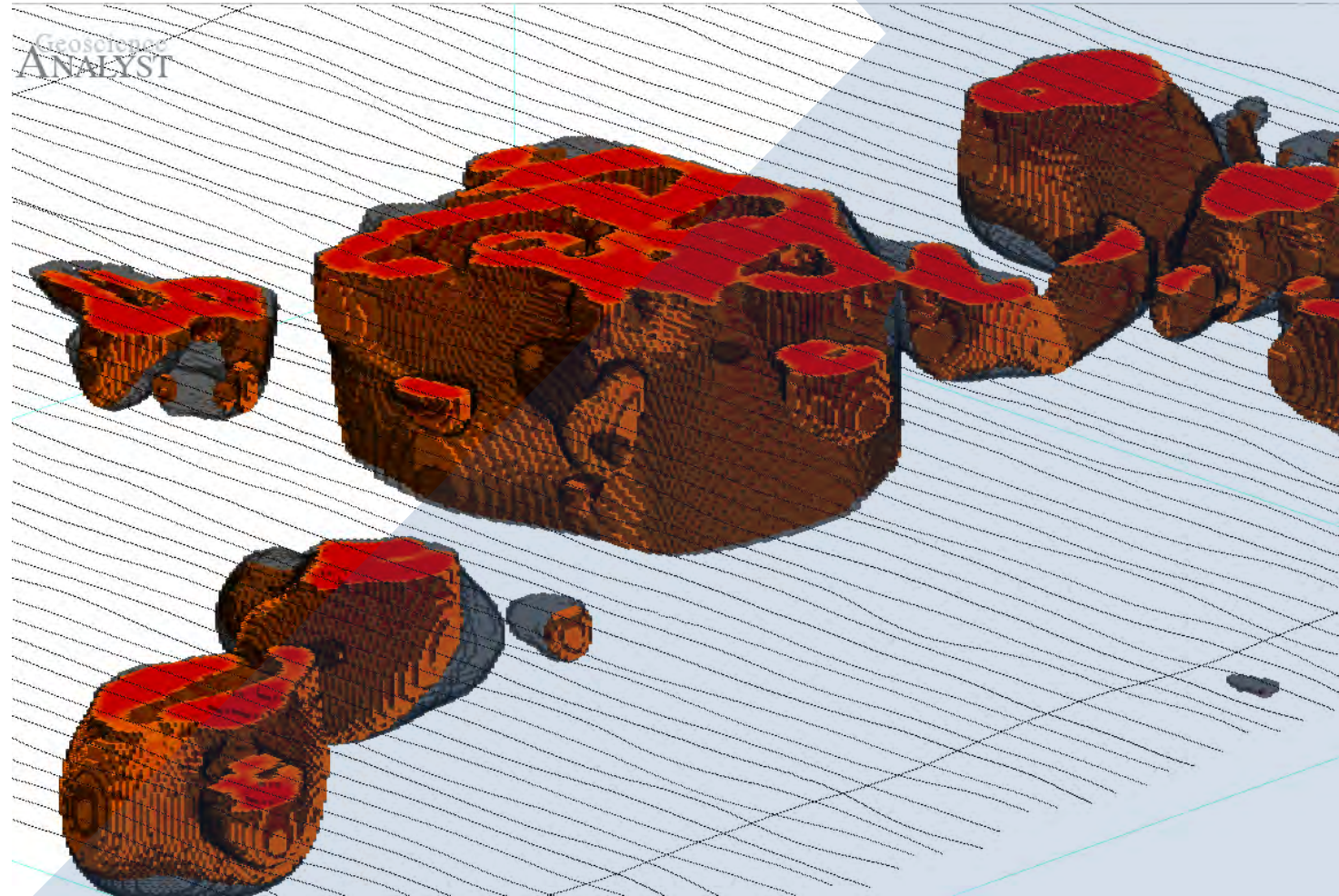



# QMAG<sup>T</sup>

AIRBORNE FULL-TENSOR MAGNETIC GRADIOMETRY (FTMG)

QMAG<sup>T</sup> 3D INVERSION AND ADVANCED PRODUCTS

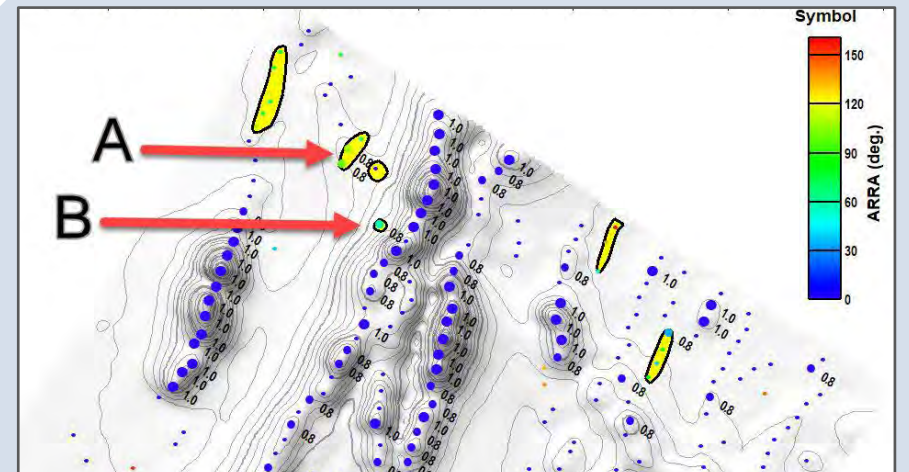
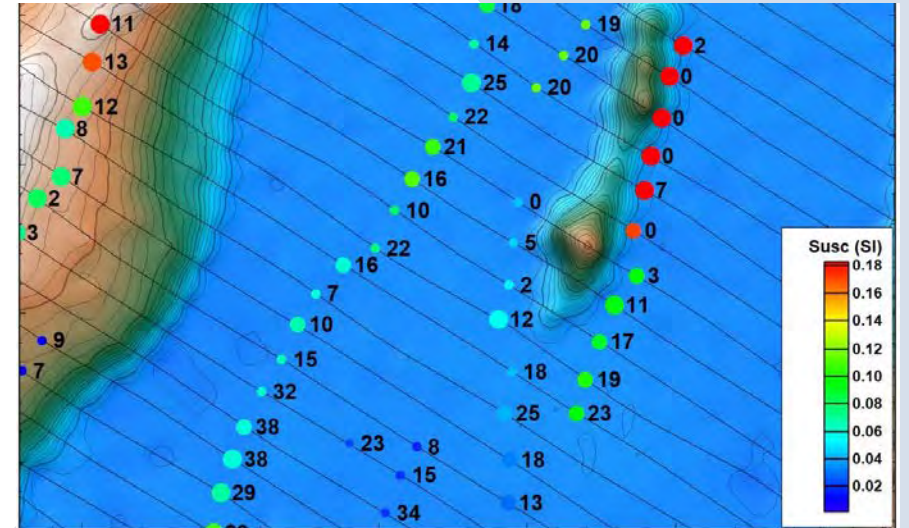
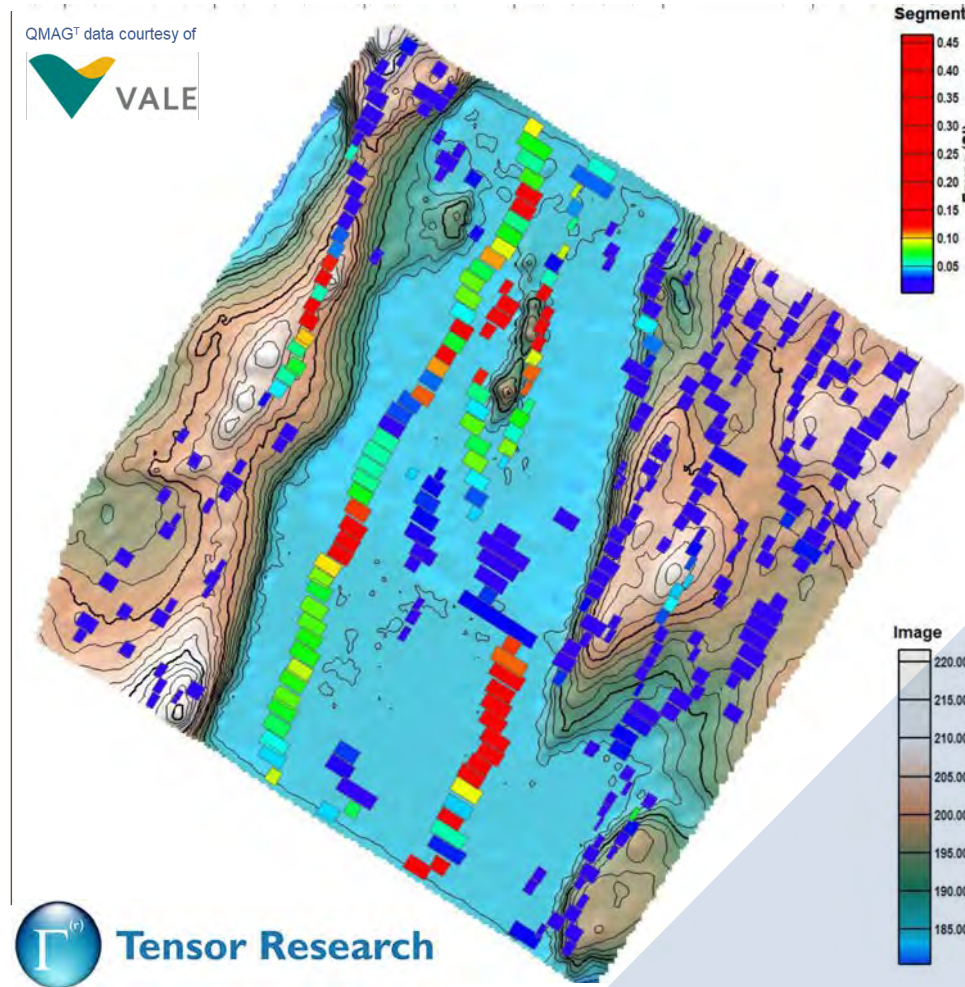

# QMAG<sup>T</sup>

AIRBORNE FULL-TENSOR MAGNETIC GRADIOMETRY (FTMG)

QMAG<sup>T</sup> 3D INVERSION AND ADVANCED PRODUCTS

MAGNETIC SUSCEPTIBILITY MODEL COMPARISON INVERTED FROM TMI AND FMTG DATA

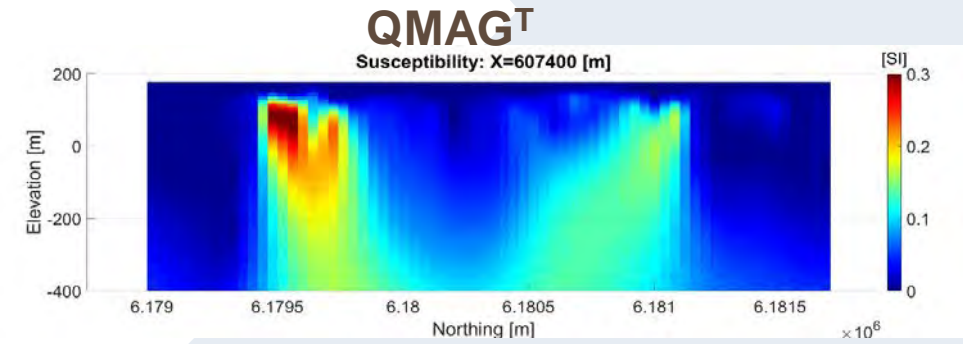
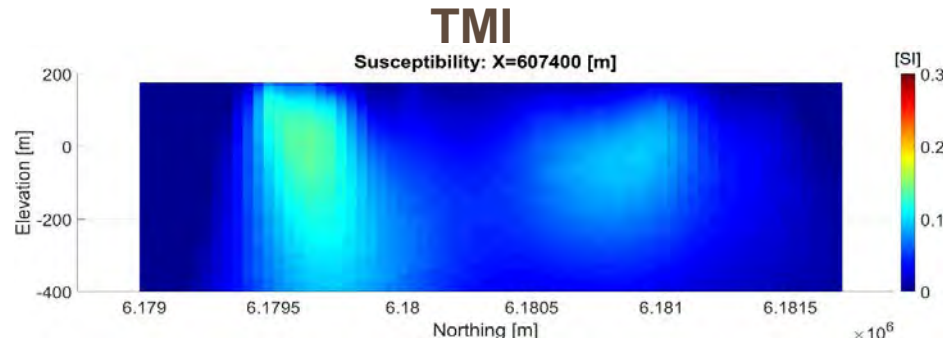

TechnoImaging has developed a regularized inversion scheme employing a focusing stabilizer and Gramian constraints to invert FTMG data. Inversion runs for both susceptibility and components of the full magnetization vector.

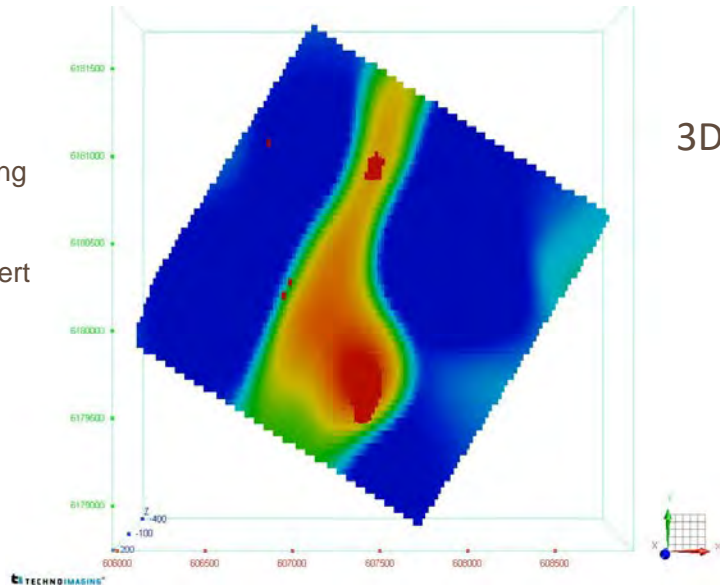

3D isobody views

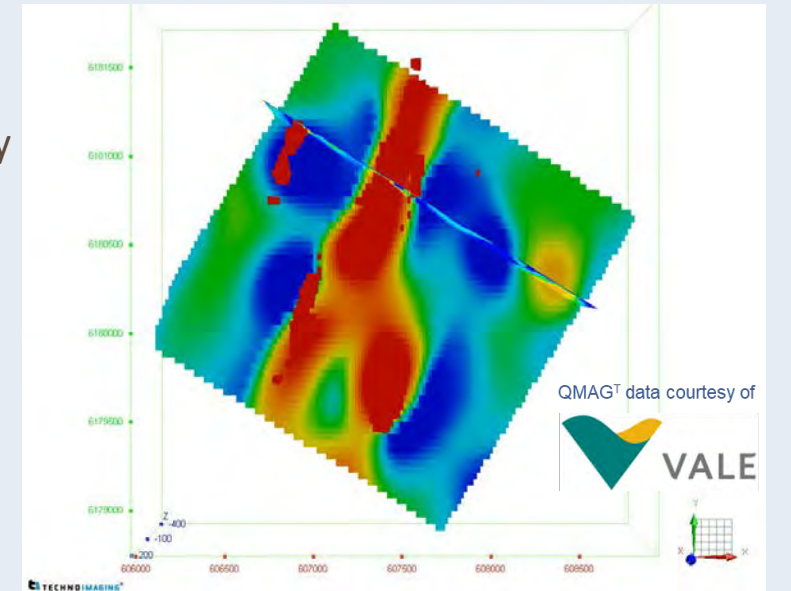

QMAG<sup>T</sup> data courtesy of  
 VALE

# QMAG<sup>T</sup>

AIRBORNE FULL-TENSOR MAGNETIC GRADIOMETRY (FTMG)

## QMAG<sup>T</sup> 3D INVERSION AND ADVANCED PRODUCTS

- Joint inversion of magnetic tensor and TMI data
- Unconstrained 3D inversion to support initial interpretation
- Deeper understanding of the geology through exploration modelling and 3D litho-constrained inversion

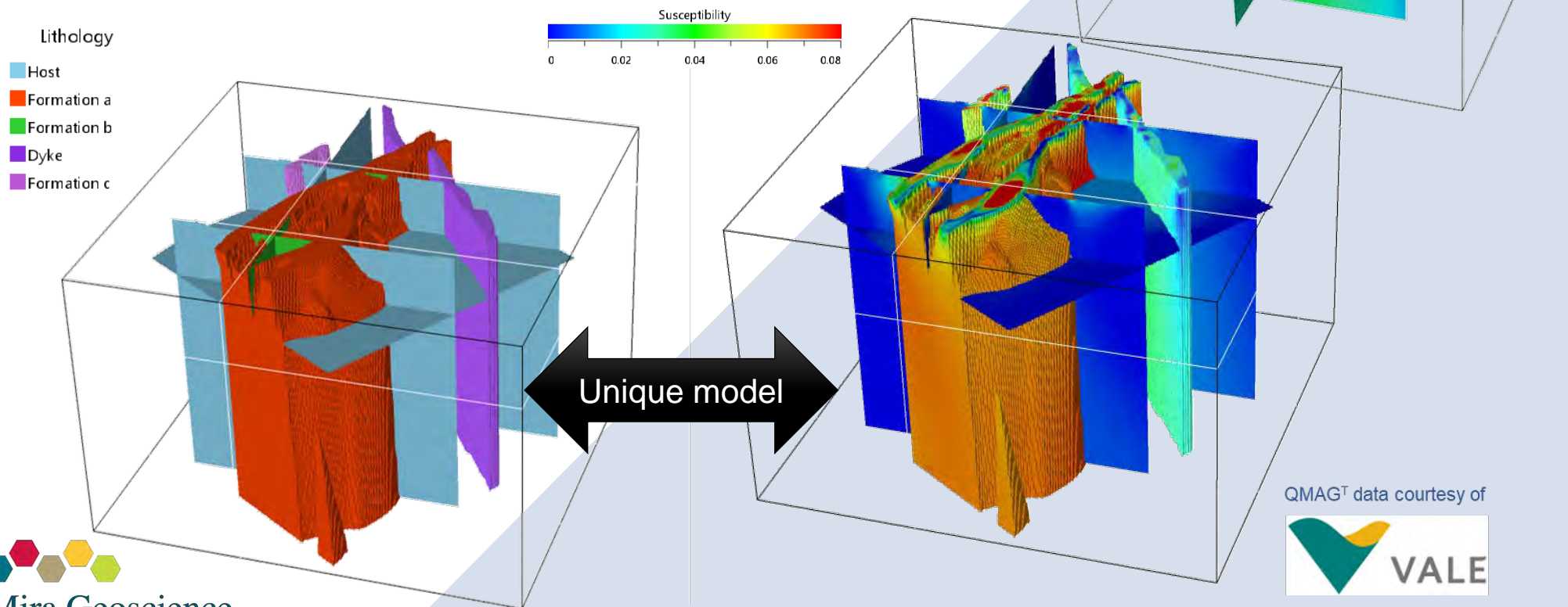

# SUB-AUDIO MAGNETICS (SAM)

Sub-Audio Magnetics (SAM) is a proprietary survey technique which requires a geophysical transmitter to transmit a precisely controlled signal into either an inductive transmit loop or a grounded dipole in order to induce secondary fields in sub-surface conductors. Using Gap Geophysics' (a Dias company) transmitters, currents of up to 200A are normally achieved with low resistance loops. Typically, 15-30A will be transmitted into a grounded dipole.

- Simultaneous and rapid acquisition of physically independent data sets (magnetics, MMR and EM).
- High-resolution, fast production, incredibly scalable technique (Ground SAM, UAVSAM, HelisAM, SAMSON, LakeSAM).
- Two primary modes of deployment – Galvanic dipole source (MMR), or inductive loop (EM)
- Can be used to see through highly conductive surface layers (salt lakes), which usually limits other electrical geophysics techniques.

A Gap Geophysics (a Dias company) TM-7 SAM Receiver is used to record the earth's total magnetic field at sample rates up to 9600Hz. The TM-7 uses a caesium vapour magnetometer sensor which provides a scalar total field measurement without the requirement of levelling or orienting the sensor.

The acquired data is post-processed to extract several parameters which relate to different physical properties of the earth. The actual parameters available are dependent on the survey configuration and may include:



# SUB-AUDIO MAGNETICS (SAM)

The acquired data is post-processed to extract several parameters which relate to different physical properties of the earth. The actual parameters available are dependent on the survey configuration and may include:

- TOTAL FIELD MAGNETOMETRIC CONDUCTIVITY (TFMMC)
- TOTAL FIELD ELECTROMAGNETICS (TFEM)
- TOTAL FIELD MAGNETOMETRIC INDUCED POLARIZATION (TFMMIP)
- TOTAL MAGNETIC INTENSITY (TMI)

Each parameter extracted from a different part of the received waveform. TFMMC is an ON-time measurement as it occurs whilst current is being transmitted into the dipole where as TFEM and TFMMIP are OFF-time measurements as they occur whilst the transmitter is switched off. TMI is recovered from the low frequency component of the waveform.

## SAM MAGNETOMETRIC CONDUCTIVITY (MMC) MODE

In this survey layout, a galvanic loop is used to inject current directly into the ground, which enables SAM to deliver high definition Total Magnetic Intensity and Magnetometric Conductivity data sets.

This type of survey better suits the detection of faults, fractures, and other geology that is detected by seeking resistive anomalies in conductive terrain.

## SAM FIXED LOOP ELECTROMAGNETICS (FLEM) MODE

In fixed loop mode, a high powered transmitter will send current through a closed loop, inducing a secondary field in the ground. SAM-FLEM delivers Total Magnetic Intensity, Total Field Electromagnetics and derived 3-component Electromagnetic data from one survey.

This technique is able to detect large conductors (such as massive sulphides) under far greater depth of cover than possible with conventional EM methods.

TECHNOLOGY	CONFIGURATION	FREQUENCY (Hz)	SAMPLE INTERVAL	ACQUIRED PARAMETERS	DAILY PRODUCTION	NOISE LEVELS
SAMSON	Fixed or Moving Loop	0.125 Hz – 1 Hz	50m	TFEM, 3-C	50+ Stations	Very Low
SAM	Loop or Dipole	3.125 Hz – 8 Hz	3m – 5m	TMI, MMR (dipole), TFEM, TFMMIP, 3-C	Up to 20 km	Medium
HelisAM	Loop or Dipole	3.125 Hz – 8 Hz	5m – 10m	TMI, MMR (dipole), TFEM, 3-C	300+ km	Low-Medium
UAVSAM	Loop or Dipole	1 Hz – 12 Hz	3m – 10m	TMI, MMR (dipole), TFEM, 3-C	100+ km	Low-Medium



## AIRBORNE EM - SUB-AUDIO MAGNETIC HelisAM

- HelisAM refers to our airborne acquisition using a helicopter. HelisAM is used commercially for large dipole (up to 12 km) SAM MMR / MMC surveys and for large scale SAM EM surveys.
- The HelisAM system consists of the Cs sensor, GPS unit and laser altimeter mounted in a towed “bird” as shown in photo below. The bird is towed with a sling to mitigate interference from the helicopter. The sling length is typically 30m. No compensation is required for aircraft pitch, roll or yaw.
- HelisAM is used for large scale SAM MMR/MMC and FLEM surveys and typically uses Tx frequencies 3.125-15Hz. Achievable sample intervals are nominally 5.0m for TMI; 20m for MMR and TFEM (depending on Tx frequency).
- Low frequency (LF) HelisAM is a variant of HelisAM where transmit frequencies as low as 2Hz are used. LF HelisAM uses a 50m sling which enables the helicopter to fly at higher elevation above ground and at a slower speed.
- HelisAM achieves much greater production rates with typical survey speeds of 80 km/h. HelisAM successfully detected the Lalor VMS deposit in Manitoba, Canada that lies between 700m – 1000m below surface.



## HelisAM BENEFITS

- Magnetic field measured up to 9600 readings/sec. (5cm. sample interval)
- Increased data resolution due to helicopters ability to fly lower and slower than traditionally used fixed wing systems
- High accuracy positioning & navigation – suitable for DTM data
- Towed bird system – no aircraft effect on magnetic data (no real-time or post processed compensation required)
- Quick data transfer from the field back to head office – same day preliminary grids available
- Helicopters superior contouring capabilities – uniform data resolution
- Minimal ferry due to ability to base close to survey area. Ideal for remote areas where no airstrips are available
- Digital video flight path available
- Aircraft equipped with satellite tracking for flight following
- Aircraft and support vehicle equipped with satellite phone and 2-way radio communications
- Experienced survey pilots and field crew
- Prompt system availability

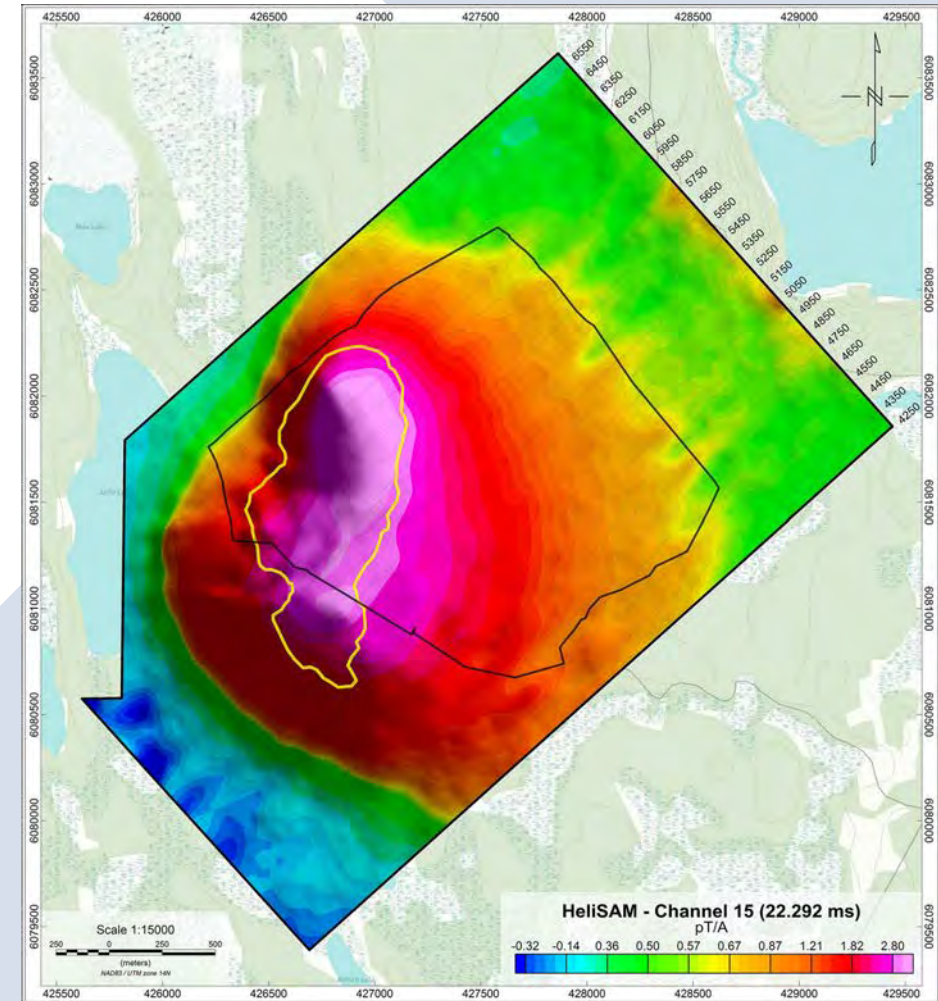

# HelisAM RAPID DEEP MINERAL DETECTION

## TOTAL B-FIELD TECHNOLOGY

- The perfect methodology for detection of large-tonnage VMS / Cu-Ni-PGM ore bodies to great depth
- ‘Seeing’ through conductive regolith or strata
- Map sheers associated with shear hosted gold mineralization
- Explore far deeper than conventional Airborne EM systems at similar pricing

## SPECIFICATIONS

- Frequency: 2 to 10 Hz
- Sample Interval: 5 to 10 m
- Daily Production: 300 km +

HeliSAM successfully detected the Lalor VMS deposit in Manitoba, Canada that lies between 700– 1000 m below surface at the typical survey speeds of 80 km/h.





# SAMSON RAPID DEEP MINERAL DETECTION

## FAST SURVEYING AT GREATER DEPTH

SAMSON utilizes our TM-7 receiver system to perform a time-domain electromagnetic survey using a total field cesium vapour sensor. It is based on our SAM technique, but instead acquires data through five minute acquisitions at fixed points, rather than being a moving survey.

In order to achieve extra low noise levels, surveys use one of Gap's high powered transmitters. Developed in collaboration with EMIT, the system can operate at the very low base frequencies needed for determining the true late-time decay constant of a deep target.

## WHY USE SAMSON?

SAMSON is one of our most sensitive Deep Search techniques. Under ideal conditions, it brings mineral exploration to the limits of financially feasible depth-of-interest. SAMSON is capable of recording data at the background noise level – meaning that this existing commercial technology is touching on the limits of what is achievable for information discrimination.

SAMSON was developed for high conductance ore bodies such as Cu and Ni Sulphide deposits.

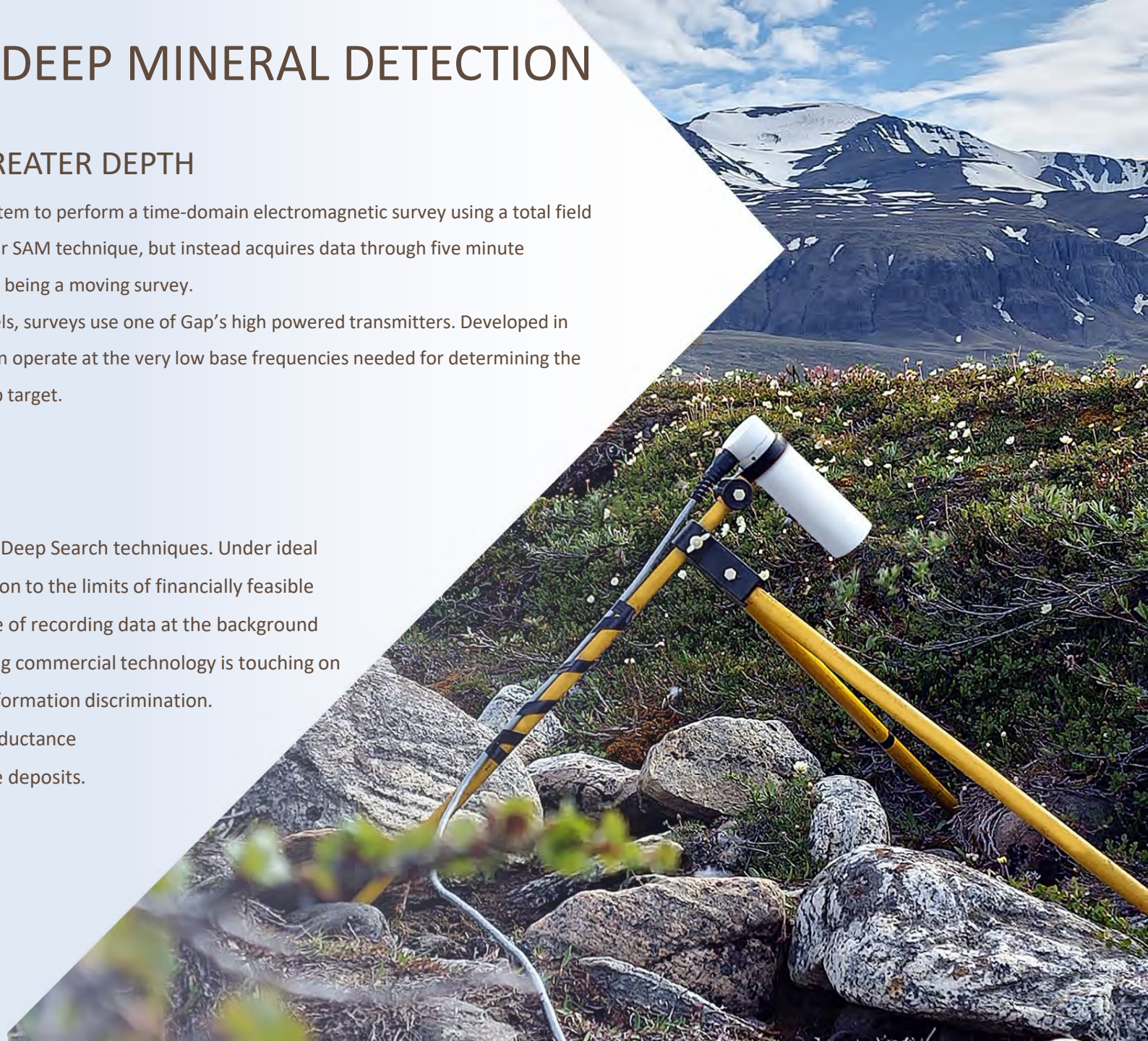

# SAMSON RAPID DEEP MINERAL DETECTION

## FAST SURVEYING AT GREATER DEPTHS

From modelling studies, a large conductive target can be detected at depths approaching 1000m or more, even under conductive cover.

The setup and time at each station is very low as the total field (scalar) measurement allows for the surveys to be logistically simple. In-built navigation helps ensure efficient terrain traversal. Surveys can be carried out in rugged terrain without the need for a level pad for the sensor. Surveys can also be carried out in windy conditions

## CONDUCTIVE TARGETS

The system is excellent at discriminating highly conductive targets – even when within conductive terrain. EMIT's Maxwell software can easily model the total field EM responses.

## SPECIFICATIONS

- Fixed loop or moving loop EM survey types
- Logistically simple – lightweight, no cryogenic cooling required
- Logging time and stack time are preset in the SAMUI control software
- Late time noise levels < 0.005pT/A (Gap Transmitter)
- Dipole, FLEM or MLEM Modes
- Sensor is mounted on a tripod carried by operator
- No orientation, levelling or stable platform required
- Immune to wind and vibration
- Low Tx frequencies – typically 0.125 to 2Hz
- Typically 3-5 minute stations
- Acquisition Rate – typically 8-12 stations per hour
- Station Spacing – typically 50 – 100m
- Line Spacing – Typically 100 – 200m
- Real-time Quality Control



# UAV SAM

UAVSAM refers to semi-airborne acquisition of the SAM geophysical technique, using an unmanned aerial vehicle (UAV). UAVSAM is used commercially for SAM MMR/MMC surveys, SAM Fixed-Loop EM surveys, and SAM Moving Loop EM surveys that require a low impact or are complicated by ground hazards.

The UAVSAM system consists of a Cs sensor, GPS unit augmented with an IMU system, and laser altimeter mounted in a towed "bird." The receiver bird sling is approximately 20m long to mitigate electrical interference from the UAV engine. No compensation is required for UAV pitch, roll, or yaw as it is a total B field magnetometer.

## BENEFITS OF UAVSAM

- UAVSAM can effectively increase the data density of traditional EM surveys while reducing the amount of time spent during data acquisition in areas of rough terrain. The need for line clearing/cutting is reduced as ground crews no longer need to traverse the survey lines.
- The UAVSAM system acquires data at speeds between 4 and 10 m/s and provides incredibly high-resolution data over conventional techniques. UAVSAM is capable of surveying between 1 and 12.5 Hz transmit frequencies, covering a wide range of applications in mineral exploration. The UAV system has been successfully tested at the Forrestania EM test range (in Australia), showcasing very high data density and reduced survey duration due to the logistical simplicity of deploying a UAV platform.



## DIAS ADVANTAGES

- Dias technologies are built for high-resolution, deep targeting and challenging conditions/terrain
- Our equipment can be transported anywhere in the world and adapted to any project requirement or challenge
- We choose our work to protect our field staff, our systems, our clients, and our surrounding environment
- Building our own also means that we can integrate customized safety features

**Dias “top notch” team credited with one of the most technically challenging surveys in BC history**

March 6, 2024

“Freeport-McMoRan funded a mapping/sampling and geophysical program at ArcWest’s Todd Creek Cu-Au project, which is situated approximately 30 km southeast of Newmont’s Brucejack Au-Ag mine and Seabridge Gold’s KSM-Iron Cap porphyry Cu-Au deposits in BC’s Golden Triangle. The program, with an approved expenditure of up to \$2.8 million, included one of the largest and most technically challenging 3D IP surveys in BC history, completed by the top notch team at Dias Geophysical. The 3D IP survey demonstrated that Cu-Au mineralized zones on the property which contain significant

MEETING & EXCEEDING  
THE CHALLENGES



## What our clients say...

“We HIGHLY RECOMMEND Dias for geophysical services & would ABSOLUTELY use Dias again for FUTURE geophysical survey work.”

---

“Dias is a fine example of SUCCESS in technical INNOVATION & provides critical services to the mineral EXPLORATION industry INTERNATIONALLY.”

---

“Thanks again for making a GOOD CALL today. SAFETY first. It’s a relief to me to know that our team is in RESPONSIBLE hands.”

---

“Your survey will continue to be the BASIS for our drill PLANNING through the summer. THANKS, we’ve found we can TRUST Dias!”

---

“Dias Airborne’s QMAG<sup>T</sup> system is the most advanced airborne magnetic system currently commercially available.”

- *Acme Lithium*

---

“The QMAG<sup>T</sup> results will greatly assist the upcoming field mapping and drill program.”

- *Lake Winn Resources*





# DIAS

LEADING GROUND AND AIRBORNE GEOPHYSICS

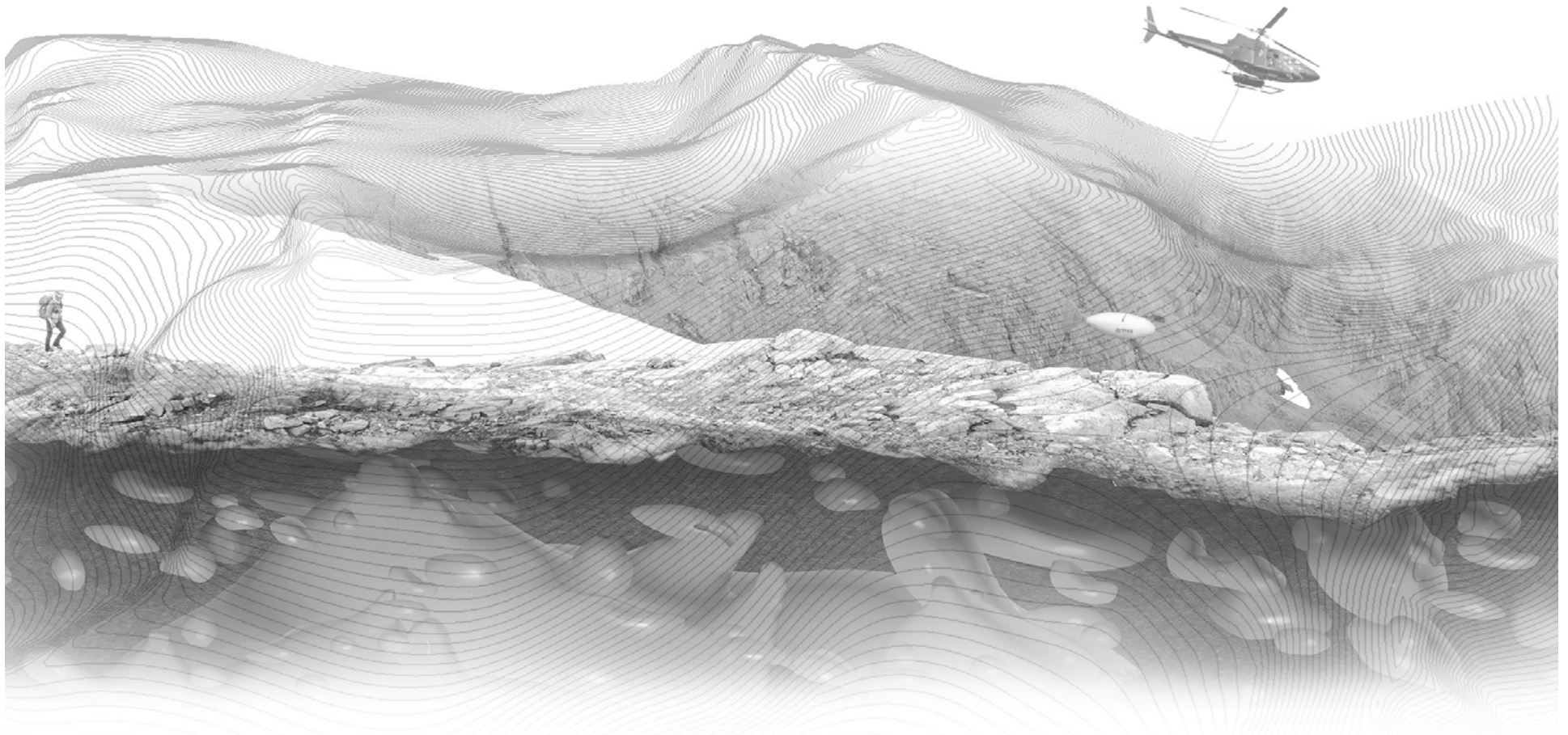

## CASE STUDIES

[WWW.DIASGEO.COM](http://WWW.DIASGEO.COM)



“The ability of the QMAG<sup>T</sup> system to detect very weak magnetic signals, and image complex directional patterns is very important to exploration for this type of challenging target.”

## PROJECT LITTLE NAHANNI PEGMATITE PROJECT

Lake Winn Resources  
Little Nahanni, NT, Canada

*Little Nahanni Pegmatite Project, NT, Canada*

### SITUATION

Dias’ QMAG<sup>T</sup> system completed a survey over Lake Winn Resources’ 100% owned Little Nahanni Pegmatite project in the Northwest Territories. The project covers 7,080 hectares that encompasses a 7 km long, and up to 500 m wide, lithium, tantalum, and tin pegmatite dyke swarm. Historical drilling and channel sampling on the Project confirms the presence of significant Lithium, Tantalum, Tin, and Cesium. Historic drilling and channel sampling has proven numerous intervals of mineralized pegmatite grading >1% Li<sub>2</sub>O over 1 m to 16.65 m intervals. Lake Winn reports that they believe that the QMAG<sup>T</sup> system has successfully mapped the LCT pegmatite dyke swarm. Anomalies coinciding with the known dykes appear to coalesce into numerous larger anomalies which range from 10 m to 100 m widths and can be intermittently traced along strike for up to 7 km. The QMAG<sup>T</sup> results are being integrated with other data sets to accelerate exploration through the project area.

### QMAG<sup>T</sup> System

The QMAG<sup>T</sup> system is a helicopter-borne magnetic survey system utilizing a SQUID (superconducting quantum interference device) sensors that measure the complete

TECHNOLOGY  
DIAS  
QMAG<sup>T</sup>  
Airborne Full-Tensor  
Magnetic Gradiometry

gradient tensor of the Earth’s magnetic field. The SQUID system was developed by Supracon AG of Jena, Germany. Operating within a liquid helium bath, the sensors measure the magnetic gradients with great sensitivity. The survey delivers 6 tensor components, each of which highlights different magnetic directions in the survey area.

### QMAG<sup>T</sup> Results and Interpretation

Figure 1 shows a colour image of the B<sub>zz</sub> data channel from the survey. The colour palette is reverse, so the zones of low gradient are the “hot” red colors and the high gradients are the cold colours (blue). The current thinking is that the LCT pegmatites have very little magnetic response, so they should image as zones of low gradient. However, when they were intruded into the surrounding sandstones, a hornfels was formed causing the relatively high vertical gradient response. Therefore, the red colors (magnetic low response) is thought to map directly the LCT pegmatite dykes. This is an exciting result.

The other QMAG<sup>T</sup> tensor images (like B<sub>xy</sub>, not shown) support this interpretation with coincident anomalies matching the linear features in the B<sub>zz</sub> image. The results show a dense swarm of pegmatites, tens of metres across near the northern drill holes. Drill hole MAC06 encountered 17.96 m of LCT pegmatite

TARGET  
LITHIUM

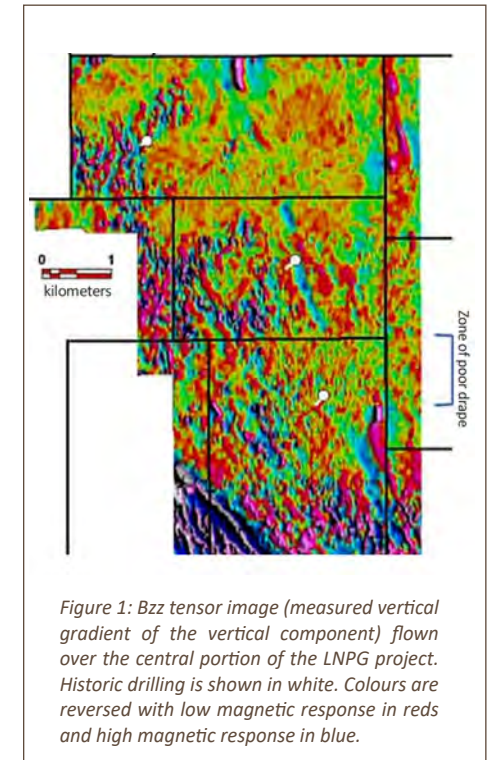

Figure 1: B<sub>zz</sub> tensor image (measured vertical gradient of the vertical component) flown over the central portion of the LNPG project. Historic drilling is shown in white. Colours are reversed with low magnetic response in reds and high magnetic response in blue.

grading 1.03% Li<sub>2</sub>O and drill MAC07 drilled from the same site at a 60° dip encountered 10.94 m of LCT pegmatite grading 1.47% Li<sub>2</sub>O (Figure 2). Figure 1 also illustrates an 80 m to 100 m wide magnetic signature that traverses the entire data set for several kilometers. This anomaly has been named Alpha Prime. Close inspection of nearby historic collars suggest they drilled near, but did not test this target. Lake Winn plans to ground truth these anomalies in the



summer of 2023.

Figure 2 illustrates the northern part of the surveyed area, around drill holes MAC 06 and 07, as a reverse-colored image and overlain by topographic contours. The interpreted LCT pegmatite dykes have been traced out with lines of white dots. They seem to get cut-off by the cirques, but Lake Winn knows from mapping that they persist in the cliff faces of the cirques. The apparent cut-off in the magnetic imaging is caused

by the loss of sensitivity due to the increased height of the sensor. Signal drops off more rapidly with increased flight height because it is a gradient system. On the upper plateau, a swarm of anastomosing dykes can be interpreted, including the dyke that was sampled by drill holes MAC 06 & 07. This magnetic data will aid in guiding further drilling across these target pegmatites.

The concept that the Alpha Prime target is part of the LCT pegmatite swarm is supported by soil

sampling undertaken in the south end of the property in 2006 and 2007.

The concept that the Alpha Prime target is part of the LCT pegmatite swarm is supported by soil sampling undertaken in the south end of the property in 2006 and 2007.

Figure 3 shows the sampling results in relation to the Alpha Prime target. The trace of the Alpha Prime anomaly has a strong, coincident Li-in-soil anomaly.

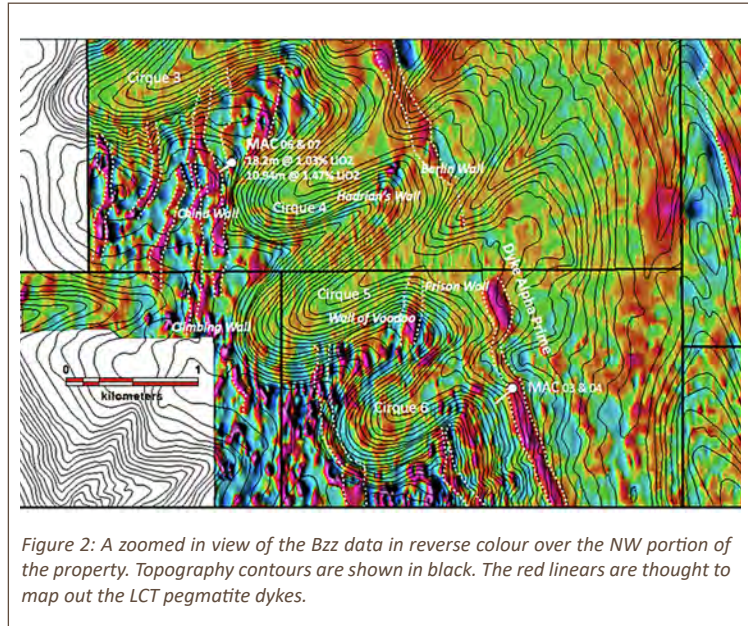

Figure 2: A zoomed in view of the Bzz data in reverse colour over the NW portion of the property. Topography contours are shown in black. The red lines are thought to map out the LCT pegmatite dykes.

## CONCLUSIONS

The QMAG<sup>T</sup> system appears to be effective in imaging an anastomosing series of LCT pegmatite dykes on Lake Winn Resources' Little Nahanni project. The dykes, as expected, are showing as low magnetic response. Weak magnetic high responses on the sides of these dykes are interpreted to be reflecting hornfels alteration during emplacement of the dykes in the sedimentary host rocks. The ability of the QMAG<sup>T</sup> system to detect very weak magnetic signals, and image complex directional patterns is very important to exploration for this type of challenging target.

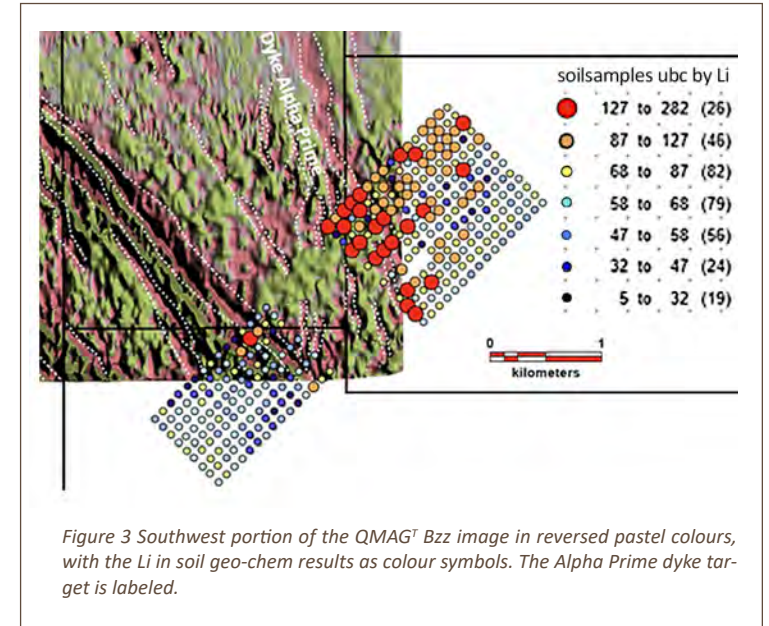

Figure 3 Southwest portion of the QMAG<sup>T</sup> Bzz image in reversed pastel colours, with the Li in soil geo-chem results as colour symbols. The Alpha Prime dyke target is labeled.







“The drill program demonstrated the QMAG<sup>T</sup> magnetic survey mapped both stratigraphy and structure related to the LCT pegmatite targets.”



WWW.DIASGEO.COM

- TORONTO
- VANCOUVER
- SASKATOON
  - MEXICO
  - CHILE
- AUSTRALIA

## PROJECT SHATFORD LAKE LITHIUM PROJECT

ACME Lithium Inc.  
Manitoba, Canada

TECHNOLOGY  
DIAS  
QMAG<sup>T</sup>  
Airborne Full-Tensor  
Magnetic Gradiometry

TARGET  
LITHIUM

*Shatford Lake Lithium Project, Manitoba, Canada*

### SITUATION

ACME’s 100% owned Shatford-Birse project area in southeastern Manitoba, Canada, is within the southern limb of the Bird River Greenstone Belt. The project is immediately south of Sinomine’s world-class Tanco Mine property, a Lithium, Cesium and Tantalum (LCT) producer since 1969. The region hosts hundreds of individual pegmatite bodies, many of which are classified as complex rareelement LCT pegmatites – known to account for a quarter of the world’s lithium production. The Shatford – Winnipeg River structure, which extends through the project area, is analogous to the Bernic Lake high strain zone that is interpreted to be related to the Tanco pegmatite. One priority area for exploration, referred to as Shatford East, is part of an approximately 7 km long curvilinear structural feature with multiple observations of pegmatites containing anomalous lithium.

The Shatford Lake property has abundant overburden, but in the broad deformation zones where most of the pegmatites occur, outcrop is virtually non-existent. In these deformation zones, overburden cover ranges up to 30 m thick. LCT pegmatites generally do not contain any ferromagnetic minerals, so do not produce

an anomalous magnetic response unless they occur in host rocks that are magnetic. The host rocks are usually also non-magnetic or have very low magnetization, so provide virtually no contrast to aid detection and delineation with conventional magnetic systems. However, it is possible that a highly sensitive gradient magnetic system could detect weak contrasts, and image structures and folding

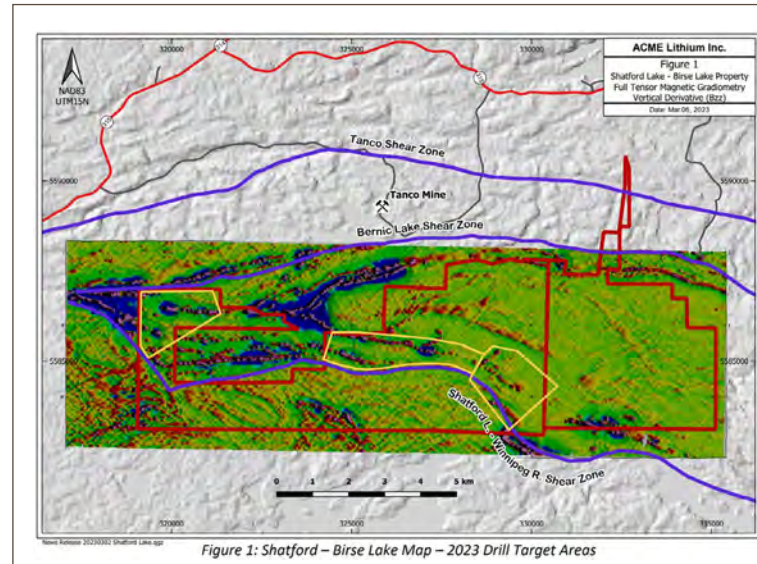

within the host rocks. Through interpretation of structure and lithology, prospective targets for pegmatite emplacement could be determined.

### SOLUTION

In the summer of 2022, ACME contracted Dias Airborne to complete a helicopter-borne

QMAG<sup>T</sup> full tensor magnetic gradiometry (FTMG) survey across the property. QMAG<sup>T</sup> is the most advanced airborne magnetic system currently commercially available. The survey comprises 1,991 line-km with a line spacing of 65 m. The FTMG survey was designed to map and characterize the variation in magnetization throughout the survey area towards interpreting structure, lithology, and alteration.

The QMAG<sup>T</sup> system measures all independent tensor components of the magnetic field using low temperature SQUID (superconducting quantum interference device) sensors. The QMAG<sup>T</sup> system provide greater sensitivity to weakly magnetic sources, higher resolution, and the directional information that allows for accurate modeling and detailed interpretation of the data sets.

### ACME Drill Targeting

ACME designed its initial 2023 drill program using the basic responses in the vertical magnetic gradient of the vertical component (Bzz). Now, modelling confirms the initial targeting and delineates additional targets. Mira Geoscience Limited (Mira) performed modelling of the FTMG data. After a preliminary interpretation, Mira performed a computationally intense Magnetic Vector Inversion (MVI) integrated with ACME and regional geological data.

Taken together with the area geology, the



priority areas for drilling are as follows (see Figure 1):

The Central Shatford area (left ellipse in the image below) is adjacent to the Tin Island pegmatite cluster. Through this area, subparallel NE trending magnetic low lineaments cross the Shatford Lake – Winnipeg Lake Shear Zone. Many prospective targets occur where NE lineaments cross the shear zone. Note the east-west, northeast and northwest trends in the batholith to the south.

The Southeast Shatford area (right ellipse Fig. 2) encompasses a substantial flexure in the Shatford Lake – Winnipeg Lake Shear Zone. This area contains a broad zone of en-echelon magnetic responses, indicating splays and dilatant zones on the northeast side of the principal shear zone, representing high-priority exploration targets.

## CONCLUSIONS

The extensive glacial till cover is transparent to

the QMAG<sup>T</sup> magnetic survey. The detailed FTMG data detects magnetite iron formation across the entire survey area and delineates the major G2 fold structures that envelope the Birse Lake pluton. A NE to ENE fracture set is evident across the entire span of the survey area, as detected in the Bzz tensor component in Figure 1.

Fine details in the vertical gradient (Bzz) adjacent to the Shatford Lake – Winnipeg River shear zone identify dilatant jogs and fold structures favourable for pegmatite intrusion. Magnetic low gaps in the high magnetic response of basalt and magnetite iron formation delineate probable pegmatite intrusion.

Vertical Derivative (Bzz) indicates that the path of the prolific Bernic Lake Shear Zone is more southerly than mapped in previous regional studies and more proximal to the Company's property.

Low contrast between the magnetic response of the pegmatites and their typical host lithologies limits the use of conventional magnetic

surveys. ACME states that, “the sensitivity of Dias Airborne’s QMAG<sup>T</sup> system and Mira Geoscience’s MVI modelling significantly alters this convention.”

Drilling commenced at Shatford Lake in January 2023 based on findings from the Summer Exploration Program and the Winter 2023 Drill Program was completed in April 2023. Eight holes were completed totaling 3,280 m of diamond drilling. Drill targets from multiple sites identified include numerous pegmatites, some of which were undocumented prior to the Summer Exploration Program. 235 samples have been cut for assay, with results pending.

Pegmatites were encountered in 6 of 8 holes and previously unknown relatively fine-grained intrusive rocks indicate the possible occurrence of unexposed potential source plutons for lithium-bearing pegmatites. The drill program demonstrated QMAG<sup>T</sup> magnetic survey mapped both stratigraphy and structure related to the LCT pegmatite targets.

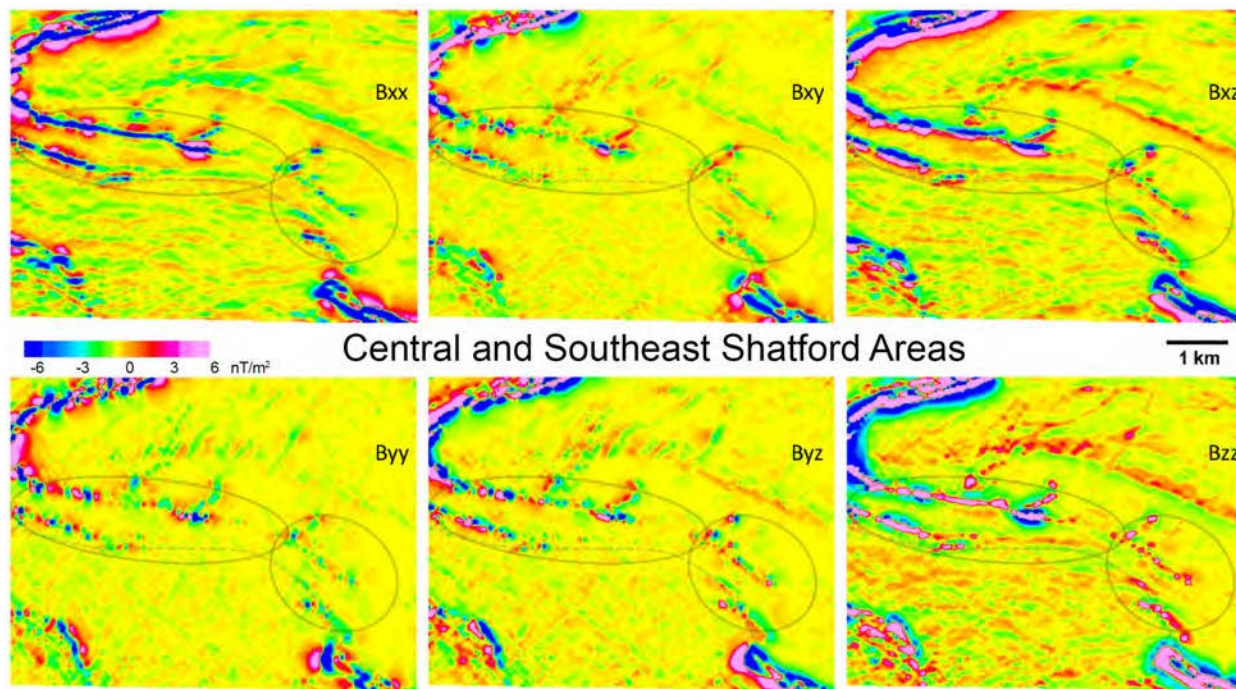

Figure 2: Central and Southeast Shatford Areas



“The ground 3D resistivity survey conducted by Dias Geophysical was key in elevating South Arrow as a high priority target that has now returned off-scale radioactivity associated with a large and robust alteration system.”

*NexGen Energy Press Release*

**DIAS**  
WWW.DIASGEO.COM

- TORONTO
- VANCOUVER
- SASKATOON
- MEXICO
- CHILE
- AUSTRALIA

## PROJECT ARROW URANIUM DEPOSIT PROJECT

NexGen Energy  
Saskatchewan, Canada

*NexGen Energy, Saskatchewan, Canada*

### OVERVIEW

Dias Geophysical successfully imaged alteration related to a known uranium deposit from 100 m depth to over 600 m depth. A similar conductive response 400 m south of the known deposit led to the discovery of the South Arrow uranium deposit.

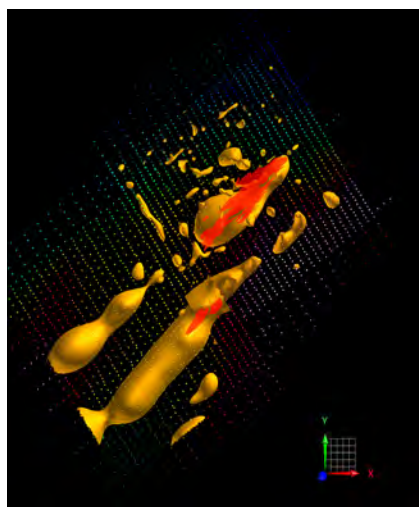

50  $\Omega$ -m resistivity iso-surface in plan view

### SITUATION

Canada’s Athabasca Basin hosts the vast majority of high-grade uranium deposits. NexGen Energy’s Arrow deposit in Saskatchewan, Canada, is the largest undeveloped uranium

TECHNOLOGY  
**DIAS32**  
Survey  
3DIP and  
Resistivity

deposit in the world. Direct detection of unconformity uranium deposits is virtually impossible with conventional geophysical exploration techniques. The DIAS32 DCIP survey was designed to image the alteration related to the high-grade uranium mineralization at Arrow, and by integration with other geologic and geophysical data sets, improve exploration efficiency.

### SOLUTION

A full 3D resistivity survey was completed across a 1.4 by 1.4 km area centered over the known deposit. A portion of the survey was completed over a large open-water lake. The multi-azimuth, and multi-scale data set was processed and inverted to generate a high-resolution 3D resistivity model of the survey area from surface to 600 m depth.

### CONCLUSIONS

The DIAS32 3D survey successfully imaged the alteration related to the Arrow high-grade uranium deposit with a high degree of correlation. A similar response in the data, 400 m south of the Arrow Deposit was drill tested and high-grade uranium mineralization was discovered. This

TARGET  
Uranium

discovery of the South Arrow deposit confirms the effectiveness of the resistivity method in the exploration for basement-hosted unconformity-related uranium deposits in and around the Athabasca basin.

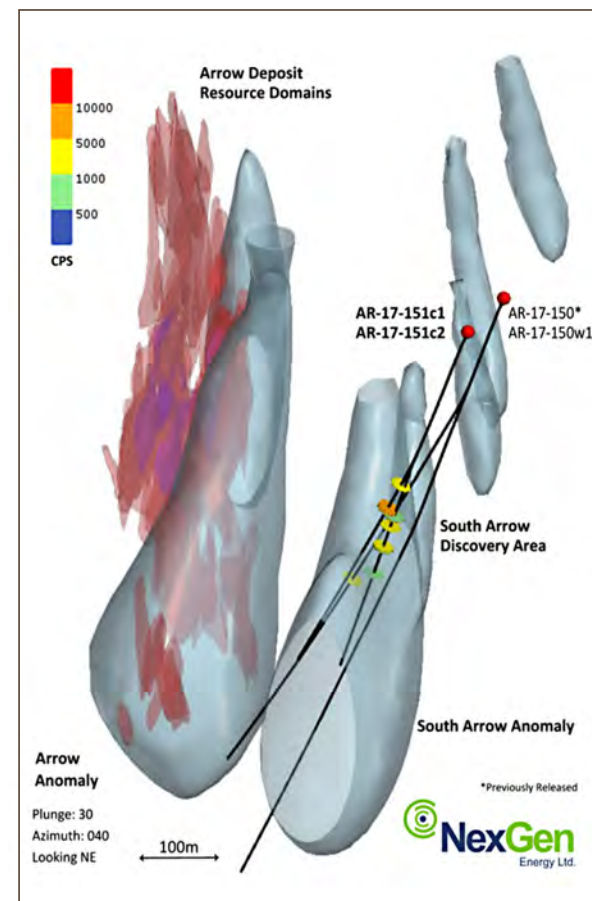

\*Previously Released  
**NexGen**  
Energy Ltd.



- High-grade, unconformity-related Uranium
- Imaged alteration plume related to uranium mineralization
- Imaged basement lithologies below 900 m depth.”

- TORONTO
- VANCOUVER
- SASKATOON
  - MEXICO
  - CHILE
  - AUSTRALIA

## PROJECT VIRGIN RIVER URANIUM

Athabasca Basin  
Saskatchewan, Canada

*Virgin River Uranium, Saskatchewan, Canada*

### OVERVIEW

Dias Geophysical successfully imaged the geological structure, lithology and alteration related to a known mineralized structure at a depth of 700 m to 900 m. The survey identifies an alteration plume emanating up from a mineralized basement fault structure.

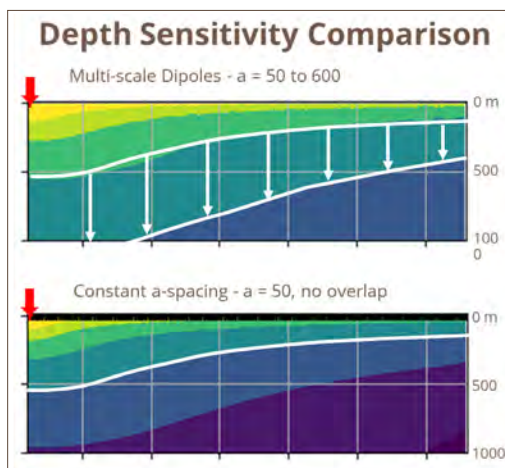

### SITUATION

Canada's Athabasca Basin hosts the vast majority of high-grade uranium deposits. The Virgin River Uranium project occurs along a major structural corridor which hosts several world-class uranium deposits. The 2D survey line was completed to

## TECHNOLOGY DIAS32 SURVEY

demonstrate the depth capabilities of the DIAS32 system in the Athabasca Basin environment. While direct detection of uranium deposits is not possible with geophysical methods, it is possible to image associated features such as the conductive graphite common in the host structures and the alteration plume that often emanates upward into the overlying sandstones.

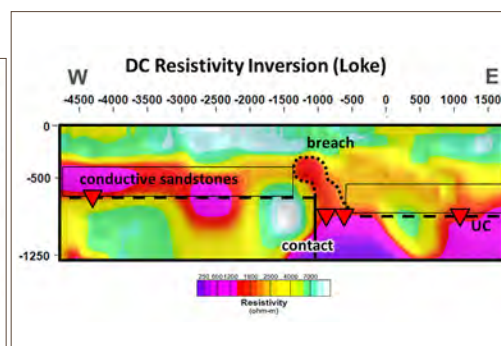

### DIAS32 SOLUTION

A 12.5 km 2D line was surveyed with the DIAS32 system across the Virgin River structure. A receiver spacing of 150 m and a current injection spacing of 75 m produced a relatively high data volume of 2D data with a-spacings of 150 m, 300 m, 450 m, etc. up to 1,200 m. This multi-scale data set was processed and inverted with the UBC-GIF and Loke RES3DINV codes to generate high-resolution 2D resistivity sections from surface to a depth of 1.2 km.

## TARGET Uranium

### CONCLUSIONS

The DIAS32 2D test survey successfully imaged the alteration related to potential uranium mineralization in an area of the Athabasca basin where the unconformity lies at a depth of 700 m to 900 m. The survey mapped variation in the bedrock beneath the unconformity and hosted unconformity-related uranium deposits.

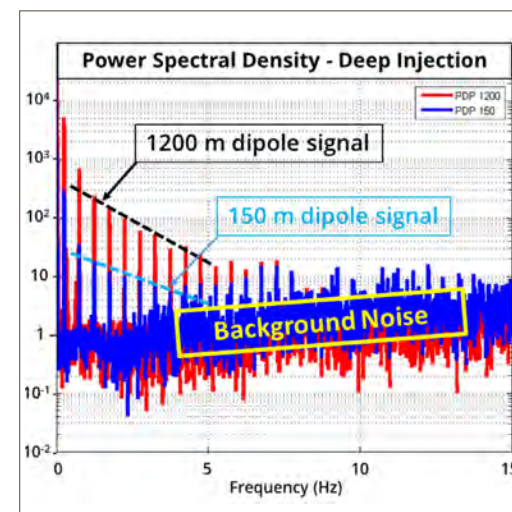

- High-grade, unconformity-related Uranium
- Imaged alteration plume related to uranium mineralization
- Imaged basement lithologies below 900 m depth



- High-grade, intrusion related gold (skarn)
- Imaged sulphides associated with gold mineralization to a depth of 300 m
- Identified several high priority targets for further exploration

**PROJECT**  
**WEEDNANNA GOLD DEP**  
Alliance Resources Limited  
South Australia

*South Australia*

## OVERVIEW

Dias Geophysical successfully imaged geological structure, lithology and mineralization at the Weednanna Gold Deposit in South Australia. A rolling 3D DIAS32 survey images the sulphide mineralization beneath ubiquitous surficial sediments with great clarity and to a depth of over 300 m. The survey generated several high priority targets.

## SITUATION

The Weednanna deposit is a magnetite breccia in carbonate altered rocks forming a skarn near the contact with a granite intrusion and containing elevated gold, bismuth, tin, uranium, lead and zinc. High grade gold is associated with sulphide replacement of magnetite. The survey area is covered by a veneer of transported sediments that makes exploration challenging.

**TECHNOLOGY**  
**DIAS32**  
**Survey**  
ROLLING 3D SURVEY

Prior to the DIAS32 survey little was known about the potential for mineralization below 200 m. The strong association of gold with sulphides makes the IP method an effective tool for imaging potential mineralization.

## DIAS32 SOLUTION

A rolling 3D survey with CVR was completed over the 1.1 km by 1.5 km survey area with the DIAS32 system. A line spacing of 50 m and a receiver spacing of 25 m provided for detailed 3D imaging of the subsurface. The CVR data set provided multi-scale and multi-azimuth data for 3D inversion. The final 3D

**TARGET**  
**Gold**

models of resistivity and chargeability were resolved to 5 m.

## CONCLUSIONS

The DIAS32 3D survey successfully imaged the mineralized system to a depth of approximately 300 m. The final 3D models of resistivity and chargeability provided insight into structure, lithology and mineralization, and several high priority targets were interpreted from integration of the survey results with other geophysical, and geological data sets.

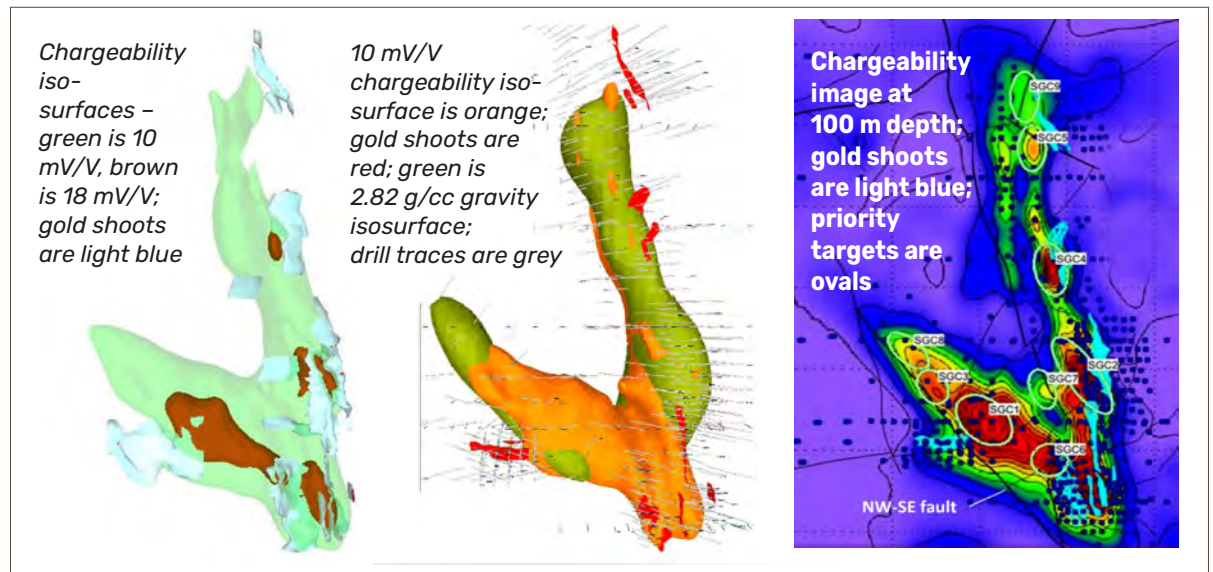



- Imaged resistive features that were successfully tested for epithermal vein mineralization
- Imaged a deep conductive and chargeable feature currently being tested as a possible porphyry source
- The DIAS32 data set assisted in upgrading the geologic knowledge of this project, moving from epithermal to porphyry

  
WWW.DIASGEO.COM

- TORONTO
- VANCOUVER
- SASKATOON
- MEXICO
- CHILE
- AUSTRALIA

## PROJECT QUARTZ RISE PROJECT

Seabridge Gold Inc.  
Northern British Columbia, Canada

*Northern British Columbia, Canada*

### OVERVIEW

Dias Geophysical successfully imaged geological structure, lithology and mineralization at the Quartz Rise project in British Columbia's Golden Triangle region. A rolling 3D DIAS32 survey images the epithermal vein systems in the near-surface, and when combined with geology and magnetic data, identifies a potential porphyry source at depth.

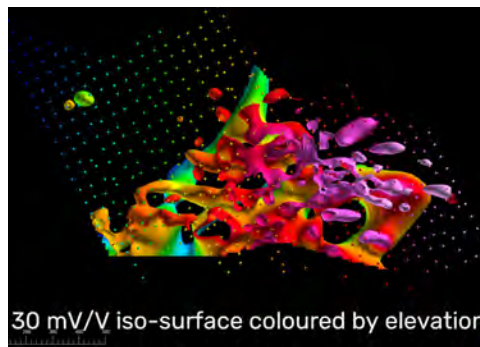
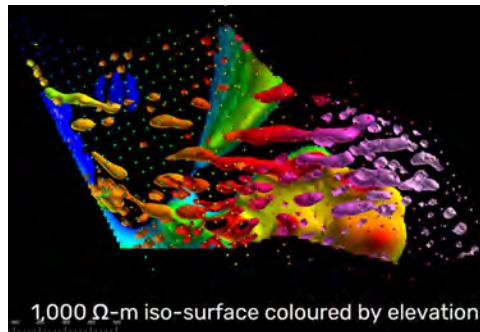

TECHNOLOGY  
**DIAS32**  
Survey  
ROLLING 3D DIAS32 SURVEY

TARGET  
**GOLD**

### SITUATION

Three years of exploration work at Quartz Rise have isolated a promising source of the lithocap above the old, high-grade Johnny Mountain Mine. Further geophysical, geochemical and geological mapping surveys have been completed, and an initial drill program totaling up to 8,000 meters has been designed to test the large intrusive system that is likely responsible for the lithocap and elevated gold and copper concentrations. This area has a geological environment astonishingly similar to KSM.

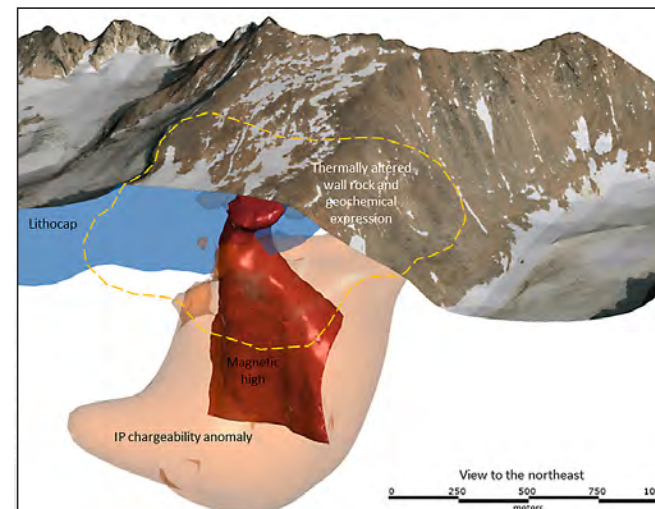

### DIAS32 SOLUTION

A rolling 3D survey with CVR was completed over the 1.5 km by 0.8 km survey area with the DIAS32 system. A line spacing of 50 m and a receiver spacing of 25 m provided for detailed 3D imaging of the subsurface given the epithermal vein target. The CVR data set provided multi-scale and multi-azimuth data for 3D inversion. The final 3D resistivity and chargeability models were resolved to 5 m.

### CONCLUSIONS

The DIAS32 3D survey imaged the vein system and identified an unexpected east-west trend. Targeting of the high resistivity features was successful, and analysis of the core identified a breccia vein, which suggests a proximal porphyry source. A successive DIAS32 survey was completed in 2019 to close out the chargeability anomaly, and integration of this data with geology, geochemistry and magnetic data, a priority target for a porphyry source was interpreted and is currently being drill tested.



- In DIAS32 surveys, dipoles are built in-line and crossline and with varying azimuths for dense, rich data sets
- DIAS32 data sets combine high resolution and depth sensitivity for robust and accurate 3D models
- Accurate models reduce exploration risk

**DIAS**  
 WWW.DIASGEO.COM

- TORONTO
- VANCOUVER
- SASKATOON
- MEXICO
- CHILE
- AUSTRALIA

## PROJECT 3D vs 2D COMPARISON

Comparison of DIAS32 3D Survey with conventional 2D

### OVERVIEW

Dias Geophysical's DIAS32 3D induced polarization and resistivity (DCIP) system is unique in its ability to deliver high volume data sets that include both multi-azimuth and multi-scale dipoles. These data sets support highly resolved and accurate 3D models of resistivity and chargeability.

### OUTCOME

In the figure below, note the significant resolution difference between the DIAS32 3D resistivity survey model (left) and the 2D model (right). In several places the apparent geologic features and trends differ significantly. In the image to the right, note the significant differences between the 2D and 3D models. The vertical sources at depth are known vertical conductive basement units. DIAS32 CVR data sets provide accurate, high resolution models for confident interpretation and follow-up.

### SITUATION

In many environments, conventional 2D DCIP surveys image the geology with a high degree of uncertainty. 2D surveys generally produce a relatively low data density and lack the ability to confidently image sources between the survey lines. As a result, there is significant

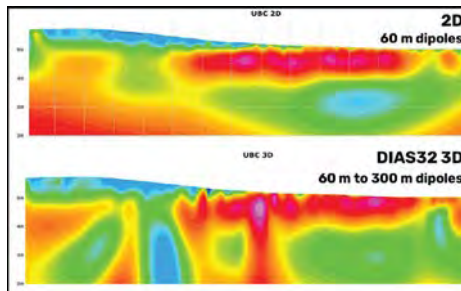

## TECHNOLOGY DIAS32

risk in targeting drill holes in complex geologic environments and the ability to accurately image deep sources is limited.

### DIAS32 SOLUTION

Dias has patented a completely new mode of acquiring IP and resistivity data called CVR. The DIAS32 system measures the response from individual electrode sensors relative to a common voltage reference (CVR) wire. DIAS32

provides advantages in safety, operational efficiency, data volume and data quality. The DIAS32 system can be deployed in any array configuration at any scale, both in 3D and 2D. CVR allows for the computation of a dipole from any two electrodes across the survey area. This yields a rich, high volume data set that contains multi-azimuth and multi-scale dipoles. Most DIAS32 surveys yield data sets of several million possible dipoles.

### CONVENTIONAL NON-CVR UNI DIRECTION MONO-SCALE



Conventional Non-CVR

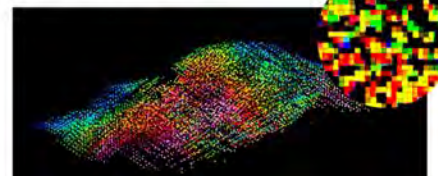

2D Survey - 250 m line spacing, 100 m dipole spacing - 3D inversion model at 100 m depth

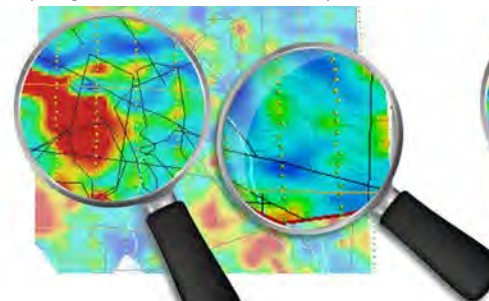

VS

### DIAS32 CVR DIPOLES

- DEPTH SENSIVITY – multi-scale dipoles
- HIGH RESOLUTION – multi-azimuth dipoles
- LOW NOISE – common mode noise rejection
- EFFICIENCY – create dipoles across challenging terrain

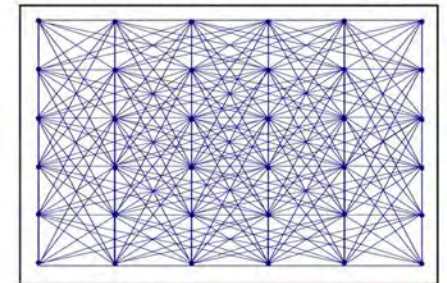

DIAS32 - MORE DATA =  
 More accurate, higher resolution models

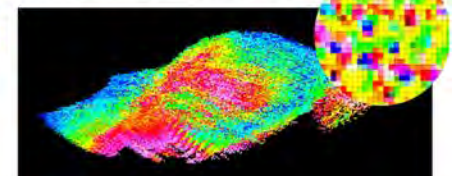

DIAS32 3D Survey - 250 m line spacing, 100 m to 800 m dipole spacing - 3D inversion model at 100 m depth

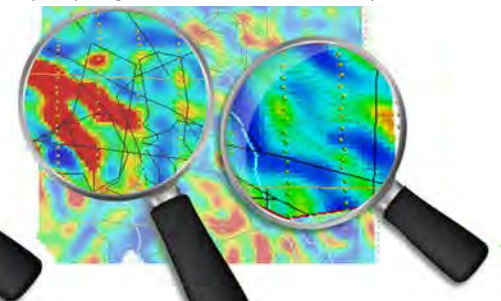



The IP anomaly correlates with the strongest surface sulfur anomaly and is the principal target for pyritic quartz vein stockwork with gold and silver mineralization.

**PROJECT**  
**BIG TEN - AMSEL PROJECT**  
VR Resources  
Nevada, USA

VR Resources, Nevada, USA

## SITUATION

The Big Ten caldera is a Tertiary-aged volcanic complex approximately 20 km in diameter in west-central Nevada. It occurs in an extensional rhyolite volcanic centre, which is analogous in age and setting to the Round Mountain Mine.

The Amsel project area lies within the Big Ten complex. Prior work has defined a 2 km X 3 km airborne radiometric potassium anomaly with a coincident robust Au-Ag-Sb-Mo soil anomaly. These anomalies plus a hilltop of silica-clay altered volcanic tuff with gold-bearing quartz

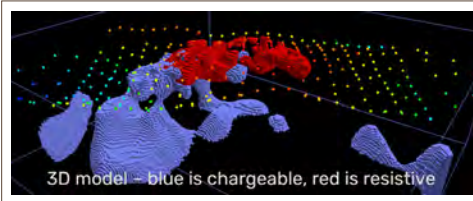

veins indicates potential for a large epithermal gold system analogous to the Round Mountain deposit, where mineralization is found below an alteration cap in a welded tuff.

## DIAS32 SOLUTION

The DIAS32 survey was designed to identify where sulphide-bearing quartz veins are concentrated within the large alteration cap and geochemical anomaly. The 3D CVR survey using 200 m line spacing and 100 m station spacing

**TECHNOLOGY**  
**DIAS32**  
**Survey**  
3DIP and Resistivity

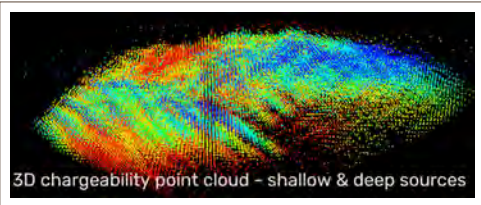

generated more than 225,000 data records from which a final data set of 95,000 data records were used for 3D inversion modelling. The survey was designed to image to over 600 m depth.

## OUTCOME

The 3D resistivity model identifies a large, nearsurface high resistivity anomaly covering a 700 m by 900 m area in the southwest quadrant of the radiometric anomaly and surface alteration zone. The high resistivity zone appears to form a cap directly above an underlying IP anomaly. The high resistivity correlates with high temperature adularia and muscovite alteration in rocks, and the strongest multi-element soil geochemical anomaly.

A section along line 8000 through the 3D IP model depicts the chargeability anomaly directly below the high resistivity zone interpreted as an alteration cap. The anomaly extends from surface to a depth of at least 600 vertical metres. The anomaly occurs below the main multi-element soil geochemical anomaly and below the area

**TARGET**  
**GOLD/SILVER**

where muscovite and adularia alteration minerals are identified in rock samples.

The IP anomaly from the 3D inversion model correlates directly with the overlying high resistivity alteration cap. It is also co-spatial with the silver soil geochemistry anomaly, and with sulfur, because the IP is expected to relate to pyrite associated with secondary hydrothermal silica. The IP anomaly correlates with the strongest surface sulfur anomaly and is the principal target for pyritic quartz vein stockwork with gold and silver mineralization.

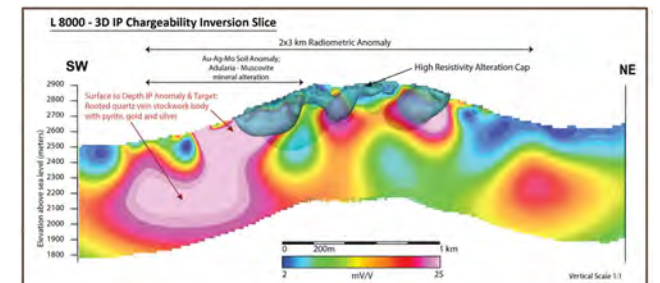
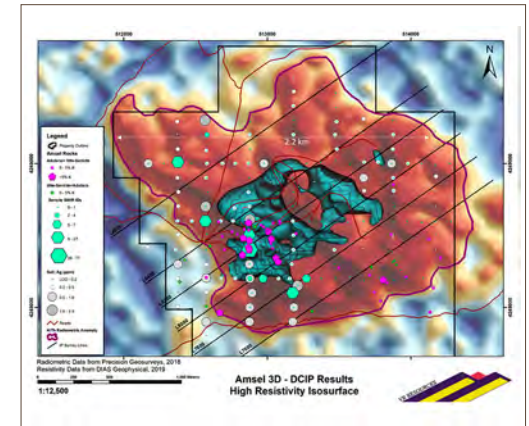





- The DIAS32 survey produced significantly higher resolution and deeper results than conventional surveys
- From the survey outcome, targeted drilling from 3D chargeability models to a depth of approximately 900 m

**PROJECT**  
**HAT PROJECT, Golden Triangle**  
Doubleview Gold  
British Columbia, Canada

*Doubleview Gold - British Columbia, Canada*

## SITUATION

The Hat Property is situated in the prolific Golden Triangle of northern British Columbia, Canada, which hosts many significant gold and copper deposits. The Hat Property is thought to host an Alkalic Copper Gold porphyry. The property is structurally complex; generally, the southwestern portion of the property has a large dioritic intrusion which is interpreted to sit on top of Stuhini group volcanics. Soil

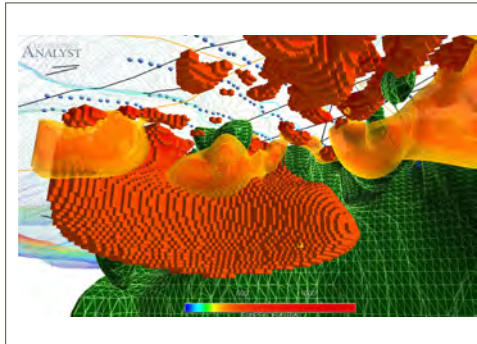

sampling has outlined several zones of copper, gold and silver near the margin of the intrusion. Historical 2D geophysical surveys have shown the IP method to be effective in detecting mineralization, but limited depth and poor resolution have hampered drill targeting.

**TECHNOLOGY**  
**DIAS32**  
**Survey**  
3DIP and Resistivity

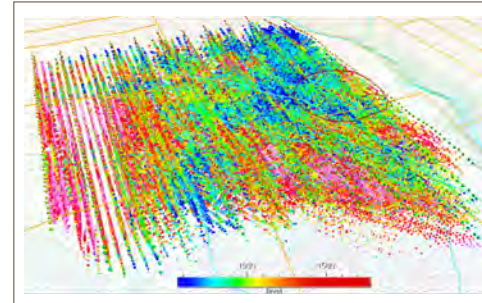

## DIAS32 SOLUTION

In 2018, Dias Geophysical was contracted to carry out a 3D DIAS32 survey across the priority portion of the property. The 9 sq. km. survey comprises 12 lines with a 250 m line spacing and 100 m station spacing. The survey was carried out in a pole-dipole configuration with common voltage referencing.

The depth of investigation was designed to be 500 m or more, and high resolution was achieved through multi-azimuth acquisition. During the QC process, approximately 10% of the DC data and 15% of the IP data were removed, leaving a high volume data set of over 100,000 data points.

## OUTCOME

Unconstrained 3D inversions for the resistivity and chargeability parameters produced robust 3D models with a near-

**TARGET**  
**GOLD**

surface resolution of 25 m. The DIAS32 survey identified an extensive chargeability high which occurs below the Lisle Zone, which had yielded encouraging drill results prior to the DIAS32 survey. The DIAS32 3D models were integrated with geological, geochemical and magnetic data sets to produce a prioritized list of targets. The subsequent drill program produced significant results in the Lisle Zone where

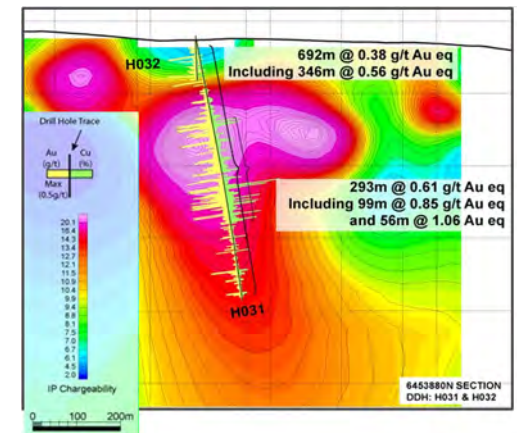

mineralization was found to occur to depths of over 700 m. Visible gold was encountered in one hole. Drill testing of hole H036 revealed an occurrence of visible gold which was accompanied by chalcopyrite, bornite and magnetite.